



# AK3000 DS3 System Quick Installation

[www.aktino.com](http://www.aktino.com)

1-888-AKTINO9

Part #	Description	CLEI Code	Kit Part #	Description
AK300C	CO DS3 line card, Full DS3 at CSA, Line powering	VAUIACMJ	AK3000C	CO DS3 Kit (AK300C & AK100S)
AK301C	CO DS3 line card, Full DS3 at CSA	VAUIACNJ	AK3001C	CO DS3 Kit (AK301C & AK100S)
AK300R	RT DS3 line card, Full DS3 at CSA	VAUIACPJ	AK3000R	RT DS3 Kit (AK300R & AK100S)
AK100S	1RU Shelf (w/ AK100F fan module)	VAMB410F		

The AK3000 DS3 product family enables point to point transport of DS3 and fractional DS3 services over bonded pairs of copper, optimized for CSA distances (9kft 26AWG or 12kft 24AWG). The AK3000 family consists of DS3 Central Office and Remote cards that plug into a 1RU high housing for 19" and 23" racks and for wall mounting. The remote card is either line powered by the Central Office card or locally powered. Aktino products utilize a technology "MIMO on DMT" which uses coordinated signal processing over multiple transceivers to achieve significant performance improvements over standard DSL technology. Refer to the AK3000 DS3 Technical Practice (180-0005-001) for more comprehensive information and troubleshooting.

Installation is identical for both the CO and RT ends.

## #1 Mounting (see Figure 1)

The AK3000 Family's shelf (AK100S) can be mounted in either 19 inch or 23 inch racks. The AK100S chassis includes flanges for both 19 and 23 inch mounting. Screws for mounting to both the chassis and the rack are included. Mounting holes are provided for flush or mid mount. The unit can also be mounted on a wall using either 19 or 23 inch flanges. An optional hinged bracket (AK100B) is available for easier wall mounted access.

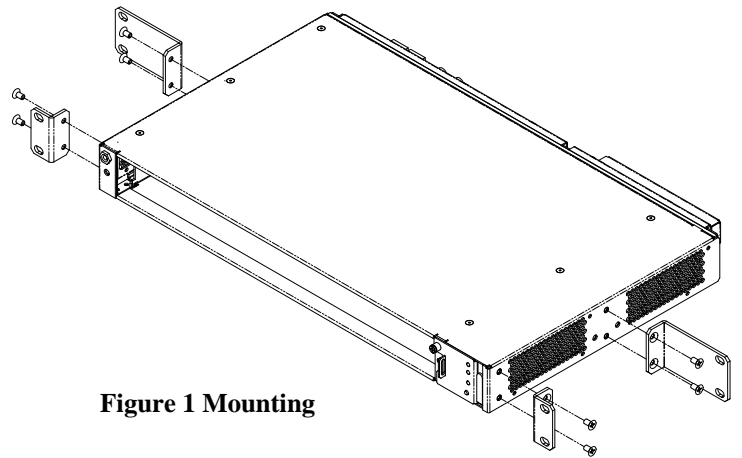

Figure 1 Mounting

## #2 Connections (see Figure 2)

### Frame Ground Connection

The Ground Lug located on the right hand side of the back panel can accommodate up to 6 AWG wire. Use a wire gauge for grounding at least as heavy as the power wiring. Attach the grounding wire to the AK100S Ground Lug to a nearby grounding screw on the equipment rack or facility ground. **Note that the ground connection is required for proper system operation.**

### Power Connection

A 7.5A to 10A UL listed fuse/circuit breaker must be installed ahead of this unit.

To access the power block, the Protective Cap located on the left hand side of the back panel must be removed. Unscrew the captive screw on the right side of the Protective Cap, slide the cap to the left and lift off. Labels of the power block and wirewrap connections are silk screened on the Protective Cap as well as the back panel.

Two redundant power buses are provided (A and B). The two power inputs are identical and can be used for redundant power configurations.

Insert the ends of the -48 Vdc and Return power wires (16 AWG wire is recommended) into the A and B holes on the left side of the power block. Route the power wires towards

the left of the back panel so that the Protective Cap can be reinstalled.

### Alarm Connections

The alarm wirewrap connections are located under the Protective Cap. Unscrew the captive screw on the right side of the Protective Cap, slide the cap to the left and lift off. Labels of the wirewrap connections are silk screened on the Protective Cap as well as the back panel. Each alarm consists of a three pin wire wrap header. These are generally only used on the CO end.

### DS3 Connection

Attach the transmit and receive DS3 coax cables to the In and Out BNC connectors on the back panel. The IN connector's shield can be grounded or opened by the slide switch below the IN connector. Generally, only one end of the DS3 coax cable shield should be grounded.

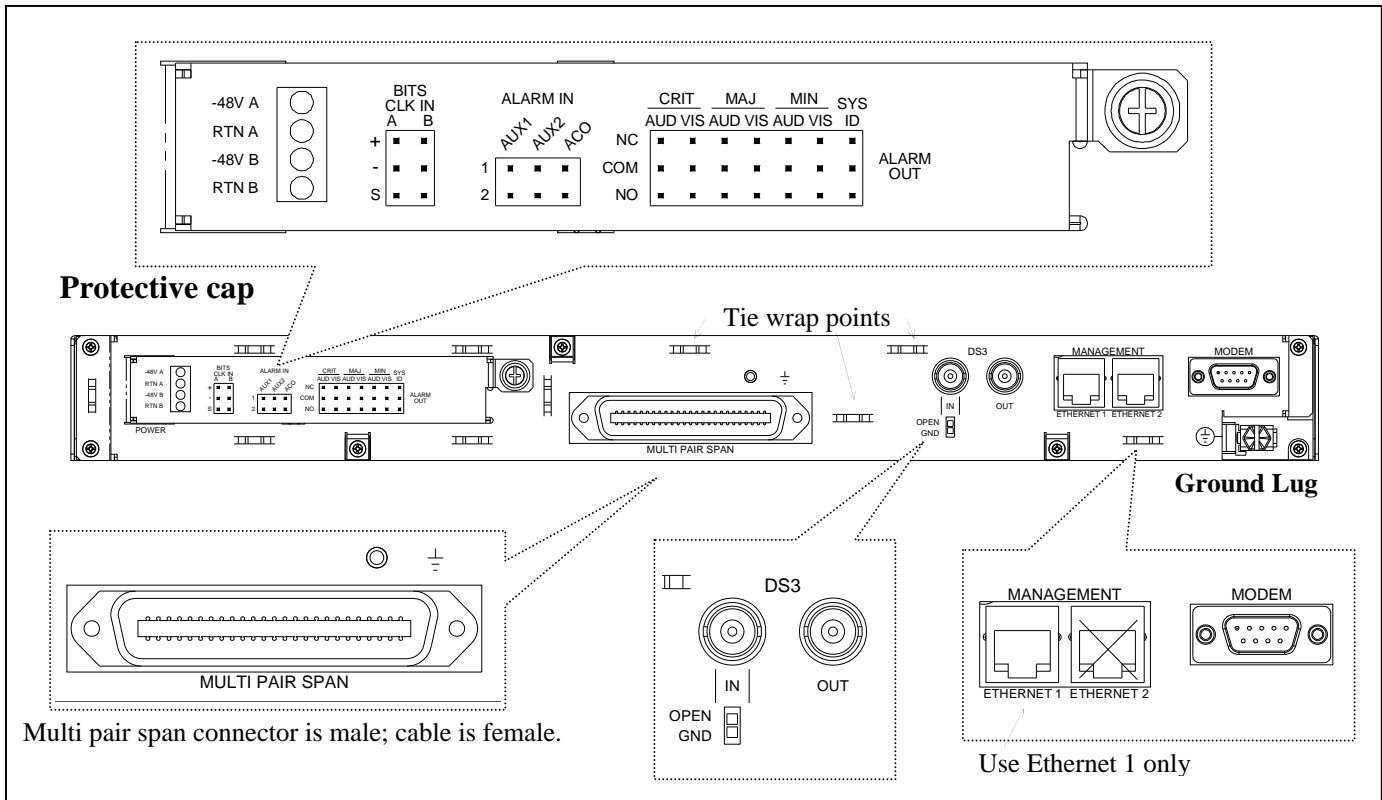

**Figure 2 AK100S Back Panel**

**Management Connection**

Ethernet 1 female RJ-45 port (located on the back panel) can be used for local or remote management access. The Ethernet port automatically is set to either 10BaseT or 100BaseT and auto-sense the polarity of TX/RX (automatic MDIX). Ethernet 2 port is not available.

**Caution** To order to comply with the intrabuilding lightning surge requirements, intrabuilding Ethernet management wiring must be shielded, and the shield for the wiring must be grounded at both ends.

The back panel RS232 modem port can be used for local or remote management access. The port is set for PPP communication for telnet or AktinoView GUI access.

The front panel Craft port is used for command line access using a terminal emulator program; AktinoView is not supported on the craft port except for IP initialization.

Management is generally attached at the CO end.

**MSPAN Connection**

The MSPAN connector is used to connect the AK3000 to the outside plant pairs. The CO MSPAN cable should be shielded with a pigtail wire that attaches to the ground lug just above the MSPAN connector. The RT MSPAN cable’s shield should NOT be connected to ground (leave open). The MSPAN cable is female. Tie wrap points are available in several places on the back panel. The MSPAN cable can be routed to the left or right.

Table 1 specifies the standard 50 pin AMP connector pin assignments.

**Table 1 MSPAN Connector Pin Assignments**

	TIP	RING
Pair 1	26	1
Pair 2	27	2
Pair 3	28	3
Pair 4	29	4
Pair 5	30	5
Pair 6	31	6
Pair 7	32	7
Pair 8	33	8
Pair 9	34	9
Pair 10	35	10
Pair 11	36	11
Pair 12	37	12
Pair 13	38	13
Pair 14	39	14

### #3 Provisioning (see Table 2)

AktinoView software is used to provision and monitor the system. Use AktinoView V3 to access the most up to date features available. Load AktinoView software onto the maintenance computer per the instructions on the CDRROM package.

#### Configuring CO Management Ethernet Port

AktinoView uses the Ethernet port 1 for access to the Aktino unit. Generally, the CO unit is used to set up the system; the RT unit can be provisioned through the CO unit.

Use *one* of the two following procedures to configure the unit's Management Ethernet port.

##### Method #1: Initialization using the front panel Craft port

- 1) Connect a serial cable between the maintenance computer and the Aktino unit's front panel craft port.
- 2) Start a terminal program such as HyperTerminal on the maintenance computer. Parameters are 9600 baud, eight bits, no parity bits, 1 stop bit, and no handshake.
- 3) After the unit has finished booting, a prompt "AKxxxx>" should appear, where xxxx is the part number of the unit. At the prompt, type act-user::loginname:::password; See \*Note below for loginname and password values.
- 4) You will be prompted to enter the following information:  
Enter TID [CO]:  
Enter IPAddress [192.168.10.1]:  
Enter NetMask [255.255.255.0]:  
Enter Gateway [0.0.0.0]:  
Enter ProxyIP-Address[0.0.0.0]: (CO only)  
Enter Date (yyyy-mm-dd)[2005-08-11]: (CO only)  
Enter Time (hh-min-sec)[13-03-24]: (CO only)
- 5) Inputs can be modified with AktinoView at a later time. Hit enter to use the default value in the brackets.
- 6) Exit the terminal program.

##### Method #2: Initialization using the Management Ethernet port

- 1) Connect an Ethernet cable between the maintenance computer and the Aktino unit's Management Ethernet 1 port located on the back of the chassis.
- 2) The Aktino CO and RT units have a factory default IP address of 192.168.10.1 and 192.168.10.2 respectively.
- 3) Configure the maintenance computer's IP address to 192.168.10.3 and Netmask to 255.255.255.0. Note the maintenance computer's original settings.
- 4) Run AktinoView using 192.168.10.1 (CO) or 192.168.10.2 (RT) as the IP address for the Aktino unit. Enter the user name and the password\*.
- 5) If desired, the Aktino units can now be provisioned with AktinoView.
- 6) If adding the Aktino unit to the local LAN, in the AktinoView GUI, under "Tools" in the top menu bar, select "Quick Provisioning".

- 7) Configure the Aktino unit's desired IP address, subnet mask, and gateway address for the local LAN.
- 8) Exit AktinoView.
- 9) Reconfigure the maintenance computer's IP address to original setting.

#### Provisioning with AktinoView V3

Connect the Aktino unit's Ethernet 1 port to the local LAN. Once the Management Ethernet port has been set up, AktinoView V3 should be started to provision the circuit.

See Table 2 below for common provisioning parameters under the AktinoView V3 Provisioning tab.

**Table 2 Common Provisioning Selections**

Parameter	Values
DS3 Format (DS3 tab)	C-bit parity Asynchronous M13 (default)
Line Build Out (DS3 tab)	0..225ft (default) 226..450ft
Payload Type (DS3 tab)	Channelized DS3 (default) ATM Scrambled ATM Clear Channel
MSPAN Mode (R2.10 or higher) (MSPAN tab)	Symmetric Asymmetric (Valid only when Payload Type is ATM or Scrambled ATM)
MSPAN Rate (MSPAN tab)	Rate (If MSPAN Mode is Symmetric) Upstream/Downstream (If MSPAN mode is Asymmetric) (Valid if Payload Type is ATM or Scrambled ATM)
MSPAN SNR Margin (MSPAN tab)	0..18db (5db default)
Line Powering (MSPAN tab)	Off, -135v, -185v (-185v default)
DS1	Select DS1 UP or Down state for fractional TDM DS3 provisioning

**\*NOTE: Default login name and password is superuser. For system security, the password for superuser should be changed.**

# #4 System Health Verification

As soon as power is applied to the CO unit (and the RT unit if locally powered), the system automatically starts up. The front panel indicators show the status of the system (see Figure 3 and Table 4). If any of the LED's is not Normal, AktinoView can be used to determine the source of the problem.

AktinoView main status screen shows an overview of the system. Performance monitoring for DS3, MSPAN, and PAIRS is available through the menu tabs. Current system alarms (see Table 3) are displayed on the main status screen. Alarm history and logs are available through the menu tabs.

**Table 3 Common Alarms (displayed by AktinoView)**

Alarm Fault	Troubleshooting
DS3 LOS	Check DS3 input connection
DS3 AIS	DS3 input is receiving AIS
DS3 LOF	Check DS3 framing configuration
DS3 RAI	DS3 input receiving RAI
MSPAN LOS	MultiPair Span pairs are down, check pairs
MSPAN Capacity	MultiPair Span capacity below configured rate; increase number of pairs or decrease system margin or reduce rate. Check Pairs PM to ensure proper operation.
Pair LOS	Pair is connected but not receiving signal, check Pair PM.
Pair Open Circuit	Pair is not connected

**Table 4 Front Panel Indicators**

LED	Condition	Function
STATUS	Off	Power off
	Green	Normal
	Red	Card malfunction
FUSE	Off	Unit fuse ok
	Red	Unit fuse has blown
ALARM	Solid green	Normal
	Solid yellow	Minor Alarm active
	Solid red	Critical or Major Alarm active
DS3 STATUS	Solid green	Normal
	Solid yellow	Network or Customer AIS
	Solid red	Network or Customer LOS
MULTIPAIR SPAN STATUS	Solid green	Normal
	Solid yellow	Minor Alarm
	Solid red	Critical or Major Alarm
PAIR STATUS	Off	Pair is disabled
	Solid green	Pair is up
	Flashing green	Pair is acquiring
	Solid red	Pair LOS/Open circuit/Short
BAT A, BAT B	Off	External DC power has not been applied
	Solid green	External DC power is present
FAN ALM	Solid green	Fan status normal
	Solid yellow	One fan has failed
	Flashing red	More than one fan has failed

**Figure 3 AK3000 Family Front Panel**

