

CONTENTS

Overview	1
Safety and Warnings	2
Introduction	4
Installation	5
Mounting the Shelf	5
Connections	6
Front Panel	8
Provisioning	9
Alarms	24
Performance Monitoring	26
Tools & Menu bar	32
Warranty and Customer Service	35

FIGURES

Figure 1 Typical Application Setup	4
Figure 2 Flange Mounting Positions	5
Figure 3 Wall Mounting	5
Figure 4 AK100S Back Panel	6
Figure 5 Power Block	6
Figure 6 AK3000 Family Front Panel	8

TABLES

Table 1 MSPAN Connector Pin Assignments	7
Table 2 RS-232 DB9 Pin Assignments	7
Table 3 Card Front Panel Indicators	8
Table 4 Fan Module ACO Pushbutton	8
Table 5 Provisioning Equipment Parameters	13
Table 6 DS3 Provisioning Parameters	14
Table 7 DS1 Provisioning Parameters	15
Table 8 ATM Inband Parameters	16
Table 8 AUX Alarm Parameters	17
Table 9 SNMP Parameters	18
Table 10 MSPAN Provisioning Parameters	20
Table 11 MSPAN Advanced Parameters	20
Table 12 PAIR Provisioning Parameters	21
Table 13 Alarm Log	24
Table 14 Alarm History	25
Table 15 DS3 Performance Monitoring Parameters	26
Table 16 MSPAN PM Parameters	27
Table 17 Summary PM Monitoring Parameters	29
Table 18 Current 15 Minutes & 24 Hours Pair PM	30

Overview

The Aktino 3000 product family enables point to point transport of DS3 and fractional DS3 services over 2 to 14 bonded pairs of copper, optimized for CSA distances (9kft 26AWG or 12kft 24AWG). The AK3000 DS3 family consists of DS3 Central Office and remote cards that plug into a 1RU high housing for 19” and 23” racks and for wall mounting. The remote card is either line powered by the Central Office card or locally powered. Aktino products utilize a technology MIMO on DMT which uses coordinated signal processing over multiple transceivers to achieve significant performance improvements over standard DSL technology.

The AK3000 family consists of the Central Office (CO) unit, the remote unit, and the 1RU shelf. Refer to the *Warranty and Customer Service* section for more information.

Inspection

After unpacking the unit, check for any damage. If damage is discovered, report it to the transportation company and to Aktino, Inc. Refer to the *Warranty and Customer Service* section for more information.

Safety and Warnings

To ensure your safety when servicing and installing this equipment, please take the following precautions:

A 7.5A to 10.0A UL listed fuse/circuit breaker must be installed ahead of this unit in the end use building installation.

A fuse panel must be installed near the unit in accordance with the National Electrical Code so that it is accessible to the operator.

A fuse panel must be provided as part of the building installation in order to provide a UL required disconnect point.

Be careful when installing or modifying telephone lines; dangerous voltages can be present. It is unsafe to install telephone wiring during a lightning storm.

Only qualified personnel should service this system.

The equipment must be connected to a protective ground in accordance with the instructions provided in this manual. Improper grounding may result in an electrical shock.

Follow local grounding practice to ensure a good frame ground connection to the Aktino chassis. The frame ground is required for secondary voltage protection.

For performance and safety reasons, only power supplies listed for use with telephone equipment by a locally recognized organization should be used with Aktino equipment.

All wiring external to the product should follow the local wiring codes.

Use of this product in a manner other than defined in this installation guide may cause damage to equipment or injury to personnel.

If a problem has been isolated to this unit, do not attempt to repair. The unit's components are not user serviceable and therefore must not be replaced. Please return the unit to Aktino for repair.

All fuses on the unit are located in non accessible areas and are not field serviceable. Please return the unit to Aktino for repair.

Observe local practice electrostatic discharge precautions when handling electronic equipment. Do not hold electronic plugs by their edge. Do not touch components or circuitry. Use a grounding wrist strap attached to grounding connection point on the left side

of the chassis. Use only ESD-protective packaging materials when transporting equipment.

To prevent ESD events when handling this equipment, ESD shoes or wrist straps should be utilized by all personnel, or ESD flooring must be present. See Figure 6 for location of wrist strap grounding connection point.



Maximum operating ambient temperature is 65°C.

Never restrict the air flow through the unit's fan or vents.

Connect the unit only to a properly rated supply circuit. Reliable earthing (grounding) of rack-mounted equipment should be maintained.

The Aktino unit contains a battery for the Real Time Clock as a convenience to maintain date and time when unit is unplugged.

CAUTION

Danger of explosion if battery is incorrectly replaced. Replace only with the same or equivalent type recommended by Aktino. Dispose of used batteries according to the manufacturer's instructions.

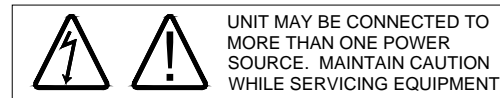

During installation and service do not connect the chassis to a live power source. Ensure that fuses are removed from the fuse panel.

This device complies with Part 15 of the FCC rules. Operation is subject to the following two conditions:

1. This device may not cause harmful interference.
2. This device must accept any interference received, including interference that may cause undesired operation.

This product is intended for installation in Restricted Access Locations only.

The Aktino AK3000 Multi Pair span interface is designed to coordinate with either a standard 300 Vdc gas tube protector unit or with a standard 300V solid-state protector. Carbon block protectors shall not be used. The 300Vdc gas tube protector shall have the performance characteristics as follows:

- DC Breakdown Voltage (Max.) 475 V @ 2000V/sec
- Impulse Breakdown Voltage (Max.) 650 V max @ 100 V/ μ sec

The 300V dc solid-state protector shall have a maximum impulse breakdown voltage of 400 V at 100 V/ μ sec, 1000 V/ μ sec and 10000 V/ μ sec.

NOTE: If line powering is enabled, voltage on MSPAN pairs is either -135Vdc or -185Vdc.

The effective capacitance of the units between the connection points for the conductors of the tip and ring

is 43.5uF. The effective capacitance of the units between the connection point for one conductor of tip or ring and earth is 0.05uF.

At the time of installation, a system assessment shall be carried out to ensure that the effective capacitance of the total system, including the capacitance of the equipment, does not exceed the values specified in UL60950.

At the time of installation, it shall be checked that the voltage rating of the wiring of the telecommunication network is adequate for the normal Aktino unit's circuit voltage, together with superimposed transients.

At the time of installation, it shall be checked that the circuits to be connected together are all AK3000 family units.

Introduction

Aktino's AK3000 family allows transport of DS3 or Fractional DS3 over bonded copper pairs. A link consists of a CO unit and an RT unit. Two types of CO units are available, one that provides line powering of the RT unit and one that does not. The RT unit is capable of being line powered by the CO unit or locally powered by a -48Vdc power supply.

The CO unit is mounted in CO racks or in Remote Terminals. Both the CO and RT units are hardened for operation in both CO and outside plant. The RT unit is mounted at the customer premises in a rack or on a wall. Both the CO and RT cards use the same chassis.

Multiple pairs are connected between the CO and RT units. The Aktino units are rate adaptable which allows DS3 rates at CSA reaches and Fractional DS3 rates over CSA reaches.

The Aktino units are carrier class providing all the required and familiar CO connections. Ease of deployment is designed into the Aktino products to make installation quick and easy.

This installation and maintenance practice goes through the steps required for successful turnup. It is very detailed to cover most questions and issues that may arise during installation and maintenance. The Aktino AK3000 Quick Installation guide (Document 180-0006-001) is normally sufficient to install the product with the practice used as a reference.

The steps are detailed in the table of contents. Generally, steps are installation of the units at the CO and customer premise, initialization of the management IP address, quick provisioning, and system health verification.

Figure 1 shows the typical application setup for the Aktino product.

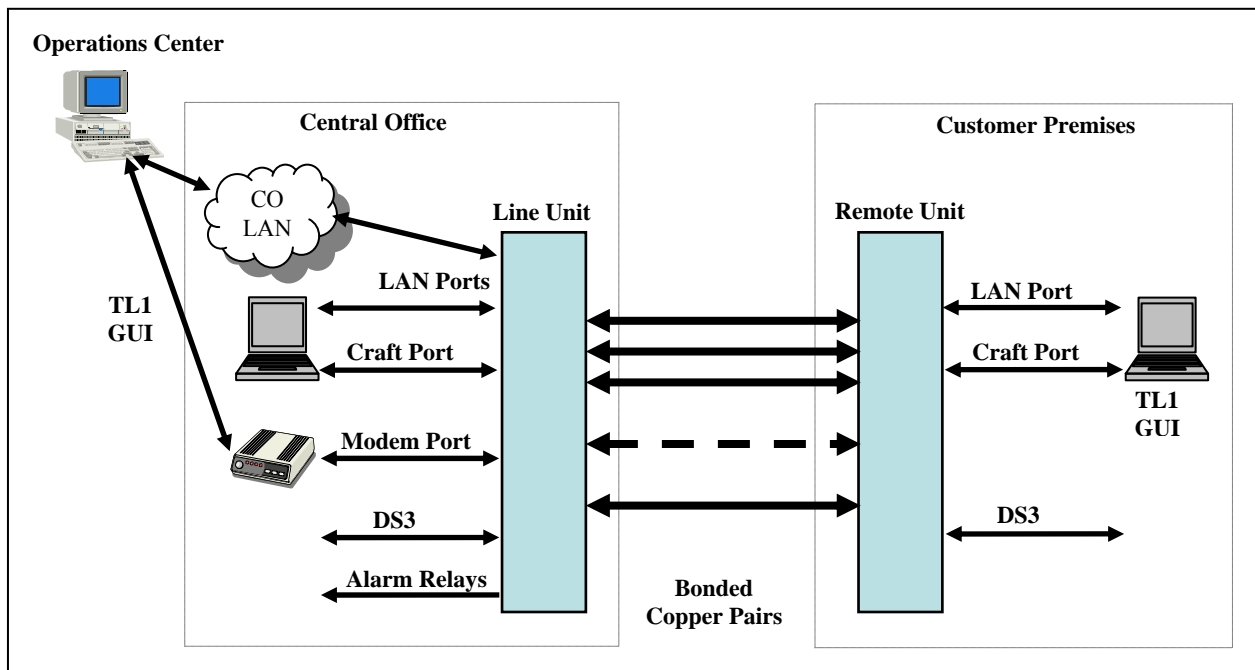

Figure 1 Typical Application Setup

Installation

The AK100S chassis is used for both the CO and RT installations.

Mounting the Shelf

The Aktino AK3000 Family's shelf (AK100S) can be mounted in either 19 inch or 23 inch racks. The 19 and 23 inch flanges and mounting screws are included in the installation kit. Mounting holes are provided for flush or mid mount. Note that the mid mount flange can be mounted forward or backward for either 5 or 6 inch recess. Figure 2 shows examples of 19 inch flanges attached to the flush position and 23 inch flanges attached to the mid mount position.

The unit can also be mounted on a wall using either 19 or 23 inch flanges. See Figure 3. An optional hinged bracket (AK100B) is available for easier wall mounted access.

It is not necessary for the flange to be bonded with the frame; the AK100S Ground Lug on the back of the shelf provides proper grounding.

NOTE The fan filter should be replaced every six months. Ordering information can be found at the end of this document.

Figure 2 Flange Mounting Positions

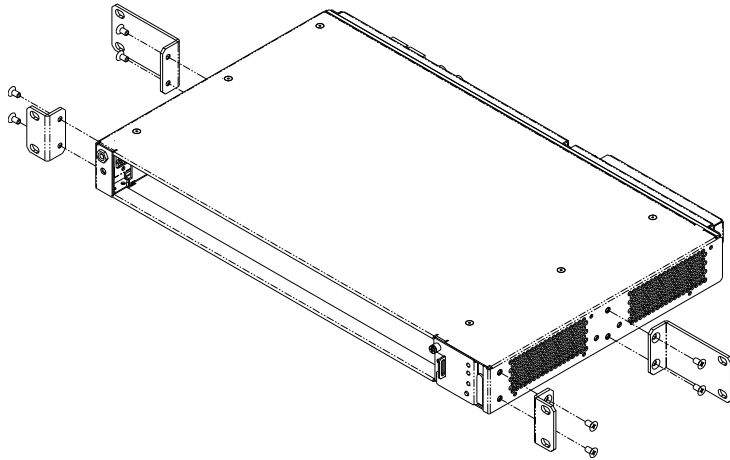
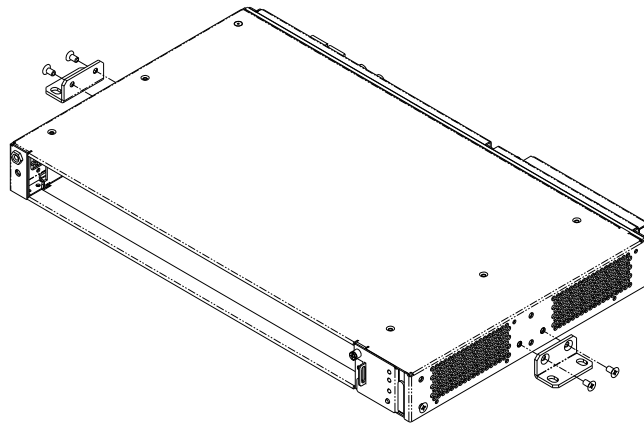

Figure 3 Wall Mounting



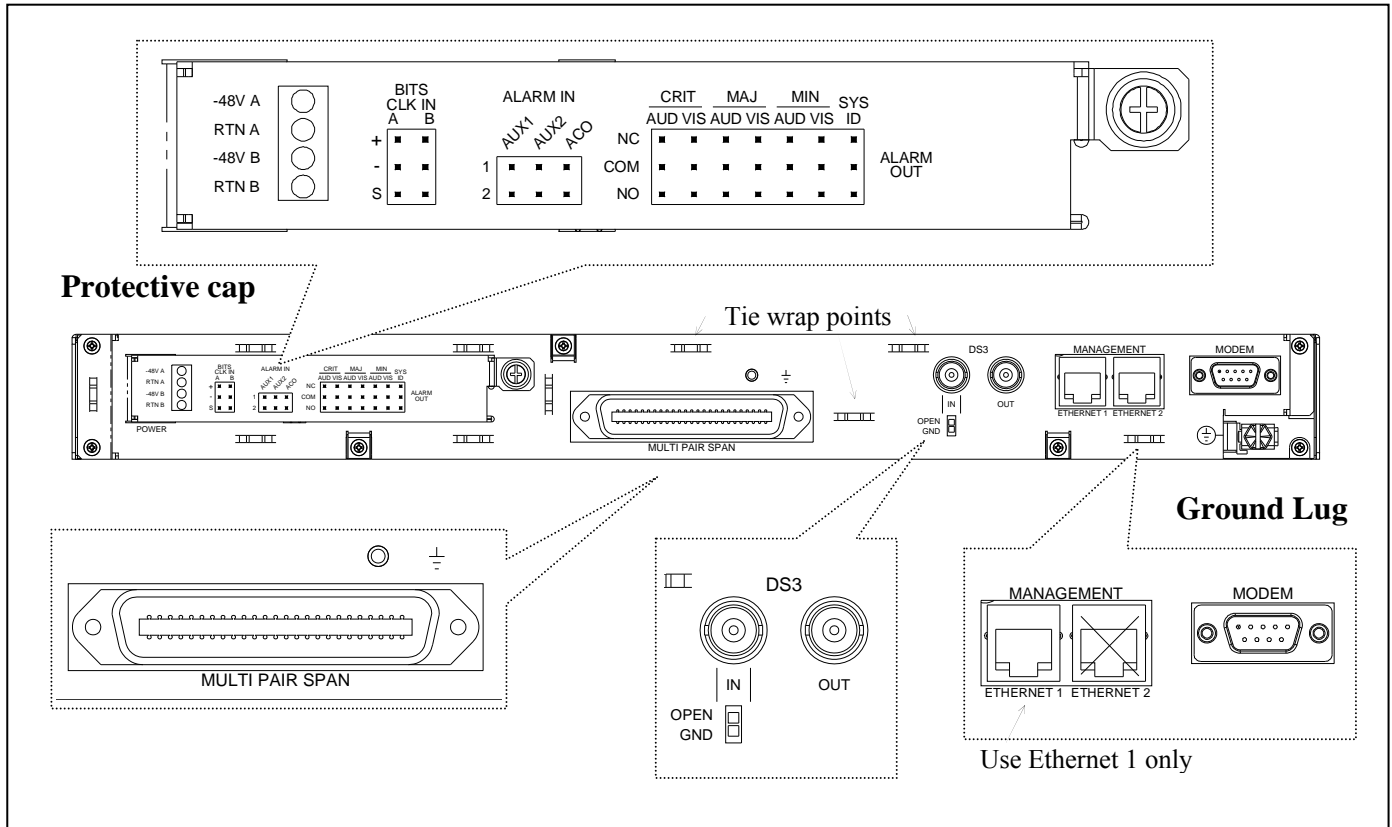

Figure 4 AK100S Back Panel

Connections

Frame Ground Connection

The Ground Lug located on the right hand side of the back panel (see Figure 4) can accommodate up to 6 AWG wire. Use a wire gauge for grounding at least as heavy as the power wiring. Attach the grounding wire to the AK100S Ground Lug to a nearby grounding screw on the equipment rack or facility ground. Test the ground connection with an ohm meter; there should be less than 2 ohms between the AK100S Ground Lug and facility ground. **Note that the ground connection is required for proper system operation.**

Power Connection

A 7.5A to 10A UL listed fuse/circuit breaker must be installed ahead of this unit.

To access the power block, the Protective Cap located on the left hand side of the back panel (see Figure 4) must be removed. Unscrew the captive screw on the right side of the Protective Cap, slide the cap to the left and lift off. Labels of the power block and wirewrap connections are silk screened on the Protective Cap as well as the back panel.

Two redundant power buses are provided (A and B). The two power inputs are identical and can be used for redundant power configurations. Unscrew the captive screw on the power block (see Figure 5). Insert the ends of the -48 Vdc and Return power wires (16 AWG wire is recommended) into the A and B holes on the left side of the power block. Route the power wires towards the left of the back panel so that the Protective Cap can be reinstalled.

NOTE: The DC return terminal is not connected to the equipment frame or the grounding means of the equipment (Isolated DC Return).

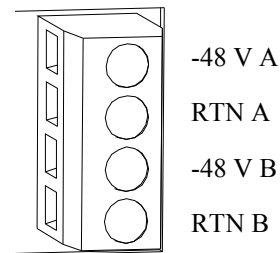

Figure 5 Power Block

MSPAN Connection

The MSPAN connector (see Figure 4) is used to connect the Aktino 3000 to the outside plant pairs. The table below specifies the 50 pin AMP connector pin assignments.

Table 1 MSPAN Connector Pin Assignments

	TIP	RING
Pair 1	26	1
Pair 2	27	2
Pair 3	28	3
Pair 4	29	4
Pair 5	30	5
Pair 6	31	6
Pair 7	32	7
Pair 8	33	8
Pair 9	34	9
Pair 10	35	10
Pair 11	36	11
Pair 12	37	12
Pair 13	38	13
Pair 14	39	14

The CO MSPAN cable should be shielded with a pigtail wire that attaches to the ground lug just above the MSPAN connector. The RT MSPAN cable's shield should NOT be connected to ground (leave open). Tie wrap points are available in several places on the back panel. The MSPAN cable can be routed to the left or right.

Alarm Connections

Alarm connections are generally used on the CO end. The alarm wirewrap connections are located under the Protective Cap (see Figure 4). Unscrew the captive screw on the right side of the Protective Cap, slide the cap to the left and lift off. Labels of the wirewrap connections are silk screened on the Protective Cap as well as the back panel. Each alarm consists of a three pin wire wrap header. Alarm connections available are:

- Critical, audio and visual
- Major, audio and visual
- Minor, audio and visual
- SysID
- Alarm CutOff (ACO)
- Aux1, Aux2 Alarm In

Each alarm can be connected to Normally Open (NO) or Normally Closed (NC) position. Use the Common (COM) pin to complete the connection. SysID wirewrap contacts can be used to identify the equipment in alarm. SysID is active during any alarm

activation. Aux1 and Aux2 are input alarm dry contact relay points. The Alarm CutOff (ACO) wirewrap pins are input dry contact relay points used for remote activation of ACO. The BITS Clock wirewrap pins are reserved for future use.

DS3 Connection

Attach the transmit and receive DS3 coax cables to the In and Out BNC connectors on the back panel (see Figure 4). The IN connector's shield can be grounded or opened by the slide switch below the IN connector. Generally, only one end of the DS3 coax cable shield should be grounded.

Management Connections

Ethernet 1 female RJ-45 port (located on the back panel) can be used for local or remote management access. The Ethernet port automatically is set to either 10BaseT or 100BaseT and auto-sense the polarity of TX/RX (automatic MDIX). Ethernet 2 port is not available.

Caution To order to comply with the intrabuilding lightning surge requirements, intrabuilding Ethernet management wiring must be shielded, and the shield for the wiring must be grounded at both ends.

The back panel RS232 modem port is not usable with R3.2.x software.

The front panel Craft port is used for command line access using a terminal emulator program; AktinoView is not supported on the craft port except for IP initialization. The DB-9 female RS232 port pin assignments are shown below; note that only pins 2, 3, and 5 are active on the front panel Craft port.

For both the back panel RS232 modem port and the front panel Craft port, the settings are 9600 baud, 8 data bits, no parity, and 1 stop bit.

Management is generally attached at the CO end.

Table 2 RS-232 DB9 Pin Assignments

RS-232 Signal	Pin
DCD	1
Receive Data*	2
Transmit Data*	3
DTR	4
Ground*	5
DSR	6
RTS	7
CTS	8
RI	9

* Front panel Craft port uses pins 2, 3, and 5 only.

Front Panel

Figure 6 shows the AK3000 family front panel. The AK3000 family kits consist of an AK3xx Line card and the AK100S shelf. The AK100F fan module is included with the AK100S shelf. The CO and RT kits have identical front panel indicators and functions.

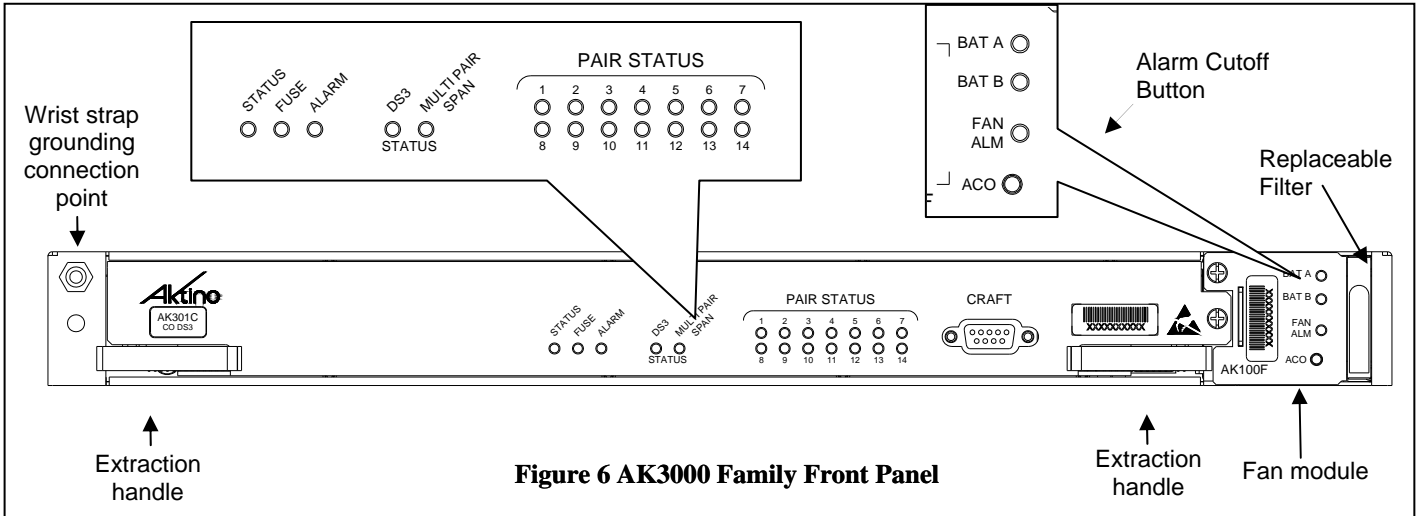

Figure 6 AK3000 Family Front Panel

Table 3 Card Front Panel Indicators

LED	Condition	Function
STATUS	Off Green Red	Power off Normal Card malfunction
FUSE	Off Red	Unit fuse ok Unit fuse has blown
ALARM	Solid green Solid yellow Solid red	Normal Minor Alarm active Critical or Major Alarm active
DS3 STATUS	Solid green Solid yellow Solid red	Normal Network or Customer AIS Network or Customer LOS
MULTIPAIR SPAN	Solid green Solid yellow Solid red	Normal Minor Alarm Critical or Major Alarm
PAIR STATUS	Off Solid green Flashing green Solid red	Pair is disabled Pair is up Pair is acquiring Pair LOS/Open circuit/Short
BAT A, BAT B	Off Solid green	External DC power has not been applied External DC power is present
FAN ALM	Solid green Solid yellow Flashing red	Fan status normal One fan has failed More than one fan has failed

Table 4 Fan Module ACO Pushbutton

Pushbutton	Function
ACO	Push Alarm Cut Off pushbutton for at least ½ second, deactivates audio (not visual) relay for all active alarms. The ALARM LED on the Aktino card indicates ACO has been activated. Note that ACO can also be activated by the wirewrap connection on back of unit.

Provisioning

AktinoView GUI V3 software is presented as the preferred means of maintenance access. TL1 commands are available.

AktinoView V3 software is used to provision and monitor the system. Load AktinoView V3 software onto the maintenance computer per the instructions on the CDROM package.

Note: AktinoWeb web browser is an alternative method of maintenance access. Simply enter the IP address of the Aktino unit in the address bar of a web browser. Features not available in AktinoWeb vs. AktinoView are:

- System Backup and Restore
- System/Slot Software Upgrade
- Export Alarm Log, Alarm History and PM
- Automatic update for configuration changes from other interfaces (AktinoView, AktinoEMS, CLI)
- No circuit display (CO-RT) for AK5000

Configuring the Management Ethernet Port

AktinoView uses the Ethernet port 1 for access to the Aktino unit. Generally, the CO unit is used to set up the system; the RT unit can be provisioned through the CO unit.

Use *one* of the two following procedures to configure the unit's Management Ethernet port.

Method #1: Initialization using the front panel Craft port

- 1) Connect a serial cable between the maintenance computer and the Aktino unit's front panel craft port.
- 2) Start a terminal program such as HyperTerminal on the maintenance computer. Parameters are 9600 baud, eight bits, no parity bits, 1 stop bit, and no handshake.
- 3) After the unit has finished booting, a prompt "AKxxxx>" should appear, where xxxx is the part number of the unit. At the prompt, type act-user::loginname::password; See *Note below for loginname and password values.
- 4) You will be prompted to enter the following information:
Enter TID [CO]:
Enter IPAddress [192.168.10.1]:
Enter NetMask [255.255.255.0]:
Enter Gateway [0.0.0.0]:
Enter ProxyIP-Address[0.0.0.0]: (CO only)
Enter Date (yyyy-mm-dd)[2005-08-11]: (CO only)
Enter Time (hh-min-sec)[13-03-24]: (CO only)
- 5) Inputs can be modified with AktinoView at a later time. Hit enter to use the default value in the brackets.
- 6) Exit the terminal program.

Method #2: Initialization using the Management Ethernet port

- 1) Connect an Ethernet cable between the maintenance computer and the Aktino unit's Management Ethernet 1 port located on the back of the chassis.
- 2) The Aktino CO and RT units have a factory default IP address of 192.168.10.1 and 192.168.10.2 respectively.
- 3) Configure the maintenance computer's IP address to 192.168.10.3 and Netmask to 255.255.255.0. Note the maintenance computer's original settings.
- 4) Run AktinoView using 192.168.10.1 (CO) or 192.168.10.2 (RT) as the IP address for the Aktino unit. Enter the user name and the password*.
- 5) If desired, the Aktino units can now be provisioned with AktinoView.
- 6) If adding the Aktino unit to the local LAN, in the AktinoView GUI, under "Tools" in the top menu bar, select "Quick Provisioning".
- 7) Configure the Aktino unit's desired IP address, subnet mask, and gateway address for the local LAN.
- 8) Exit AktinoView.
- 9) Reconfigure the maintenance computer's IP address to original setting.

***NOTE: Default login name and password is superuser. For system security, the password for superuser should be changed.**

Provisioning with AktinoView V3

Note: Use AktinoView V3 to access the most up to date features available.

AktinoView V3 System Requirements

The minimum AktinoView system requirements are:

- Pentium 4 processor-base computer
- Recommended 256Mb, Minimum 128Mb
- Microsoft Windows 2000, XP, or NT
- CD-ROM drive

AktinoView V3 Installation

- Insert the AktinoView CD in the CD ROM drive
- Open Windows Explorer and click on the CD drive option
- Double click on install.exe in the AktinoView folder
- Follow the instructions on the screen

Login Window

Once the Management Ethernet port has been set up, AktinoView should be started to continue with provisioning and verify the health of the circuit.

Upon running AktinoView V3, a login window will appear:

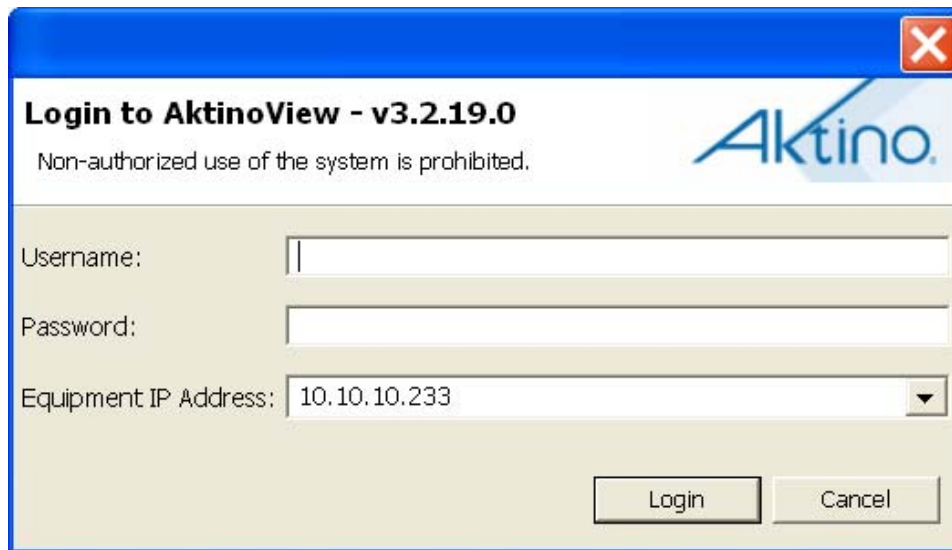

Login to AktinoView - v3.2.19.0
Non-authorized use of the system is prohibited.

Username:

Password:

Equipment IP Address:

Login Cancel

Enter IP address of the AK3000 unit username, and password. See above *Note for user name and password. To provide system security, the password for superuser and user accounts should be set up with AktinoView menus.

After logging on, the main status screen will appear:

Main Status Screen

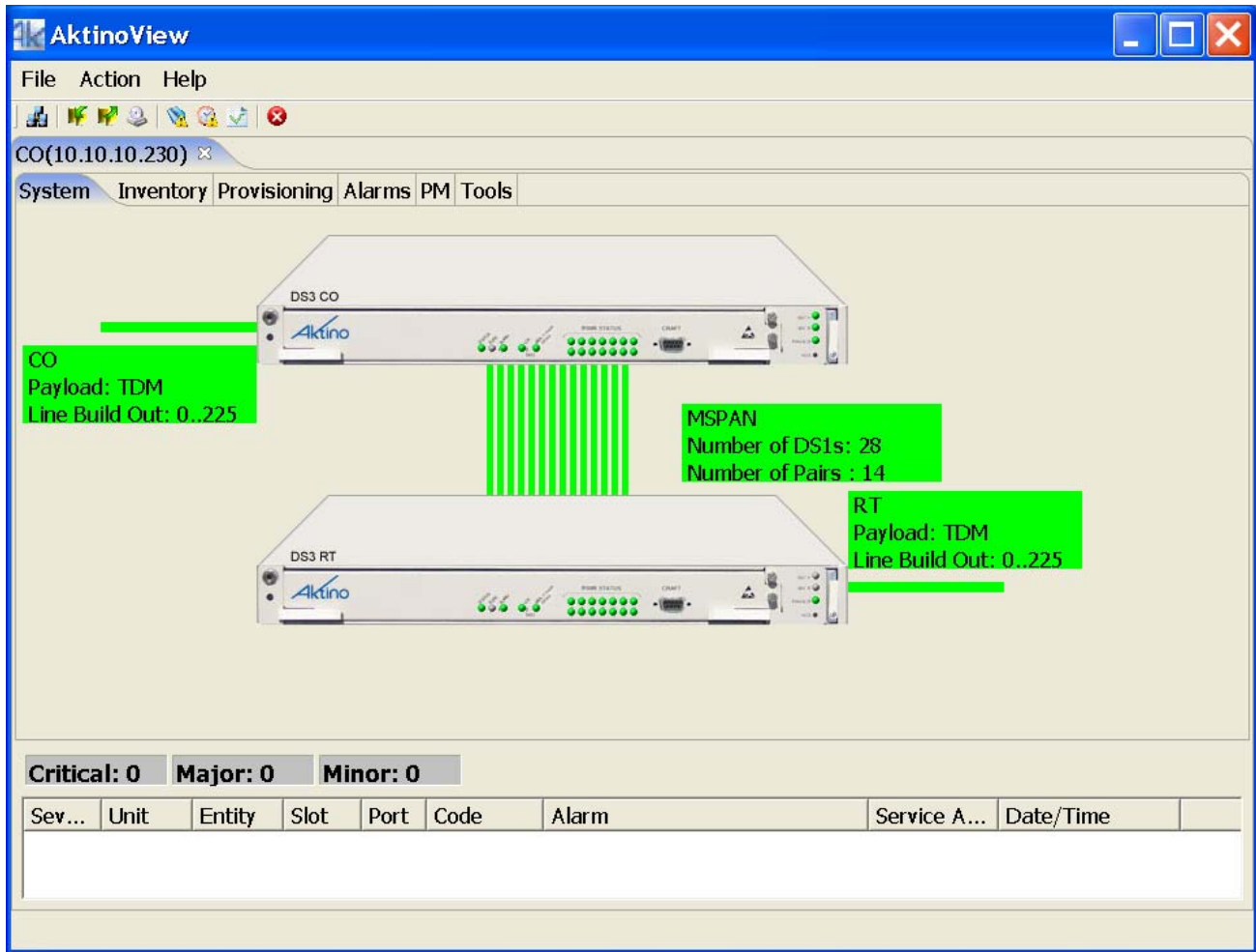

The window components consist of the following sections:

Menu bar

File, Action, and Help along with action icons.

Tabs

Allows navigation of menus for provisioning, performance monitoring, and alarms.

Workspace/Summary area

The workspace/summary area shows the CO and RT units for a quick look at the state of the system. Note that by positioning the mouse over items in the overview, a tooltip popup appears with details of the current state. This area is also used to display provisioning and performance monitoring info depending on the tab item selected.

Alarm summary

A summary of the number of alarms is provided at the lower part of the window.

Inventory Screen

Selecting the Inventory tab displays information on the system.

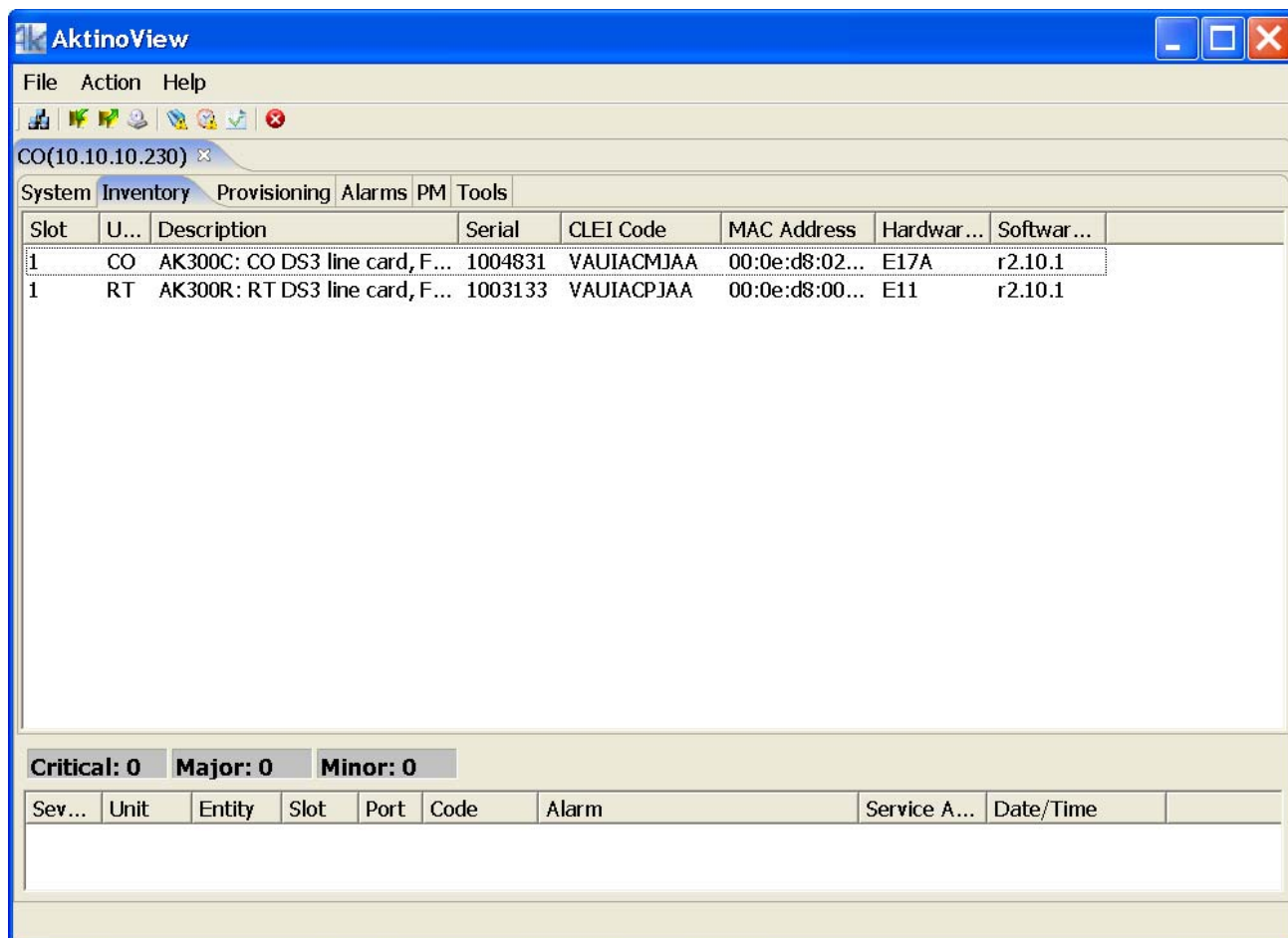

<u>Parameter</u>	<u>Values</u>
Unit	CO or RT unit
Description	Unit description
Serial	Serial number of unit
CLEI Code	Telcordia assigned CLEI code
MAC Address	Each unit has a MAC address
Hardware Version	Hardware version of the unit
Software Version	Software version of the unit

Provisioning Equipment Screen

Selecting the Equipment tab under Provisioning allows equipment provisioning of the system. Right click on unit to bring up Equipment popup. See Table 5 for parameters and values.

Slot	Unit	System ID	Contact	Location	Time	IP Address	Subnet Mask	Gateway A...	RT Proxy IP	Allow CPE Mgmt Access
1	CO	CO		lab	06/17/2008 17...	10.10.10...	255.255.0.0	10.10.10...		
1	RT	RT			06/17/2008 17...	10.10.10...	255.0.0.0	10.10.10...		YES

Table 5 Provisioning Equipment Parameters

<u>Parameter</u>	<u>Values</u>
System ID (CO only)	String describing the System
Contact (CO Only)	String describing contact
Location (CO only)	String describing location
IP Address	IP address of the Aktino unit
Subnet Mask	Subnet mask for the Aktino unit
Gateway Address	Gateway address for the Aktino unit
RT Proxy IP (CO only)	Proxy IP address for RT - Used to access RT directly
Allow CPE Mgmt Access (RT only)	YES, NO
Repeater Type (CO only)	None, Span 1, Span 2 If repeater application, indicate which span
Other Span IP Address (CO Only)	If repeater application, indicate other span IP address (do not use the same IP address as management port)
Span 2 Mgmt. IP Address (CO only)	If Span 2, indicate management IP address (do not use the same IP address as management port)
Date and Time (CO only)	Pull down buttons allow manual setting of time and date. "PC Time" sets the Aktino system to the maintenance computer's time and date. Note that the RT's time and date is updated and periodically synchronized with the CO.

Provisioning DS3 Configuration Screen

Selecting the DS3 tab under CO Unit allows DS3 provisioning of the system. Right click on the unit to bring up DS3 provisioning popup. See Table 6 for parameters and values. Note that some of the parameters changed on the CO are also reflected on the RT.

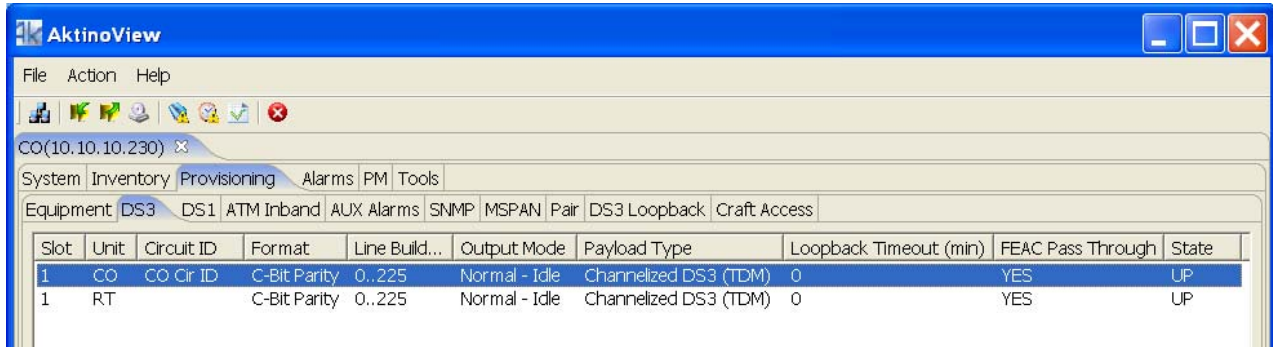
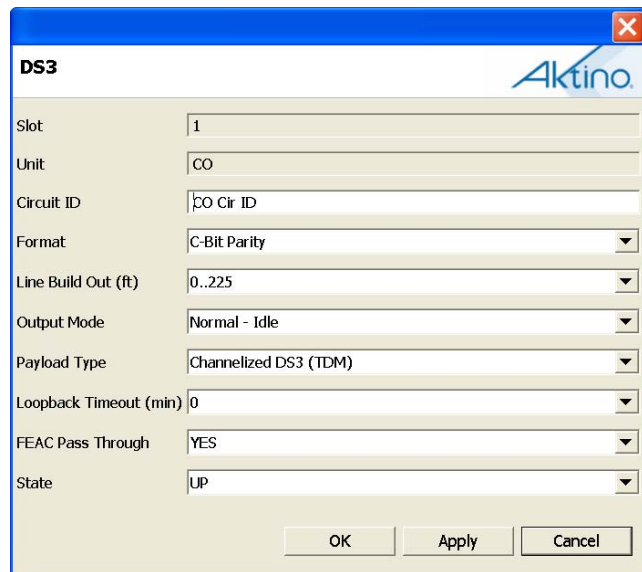

Table 6 DS3 Provisioning Parameters

<u>Parameter</u>	<u>Values</u>
DS3 Circuit ID	Allows input of description of the DS3 circuit
DS3 Line Format (CO only)	C-Bit Parity Asynchronous M13
CO unit DS3 Line Build Out	0..225ft 226..450ft
Output Mode (Alarm Pattern) (CO only)	Normal- Idle, Alarm Indication Signal (AIS)
Payload Type (CO only)	Channelized DS3 (TDM) ATM* Scrambled ATM* Clear Channel
Loopback Timeout (CO Only)	0, 20, 60, 3600(24 hours) minutes
FEAC Pass Through (CO only)	YES - DS3 FEAC loopback messages from the network are reacted upon by the CO NO - DS3 FEAC loopback messages from the network are ignored
State	UP- CO DS3 port is in service DOWN- CO DS3 port is out of service



*ATM PLCP format is not supported

Provisioning DS1 Configuration Screen

Selecting the DS1 tab under CO Unit allows DS3 tributary provisioning of the system. Right click on the Index to bring up DS1 configuration popup. Note that this screen is only active if DS3 Payload Type is set to Channelized DS3 (TDM). The MSPAN rate is set the number of DS1's set to UP state. See Table 7 for parameters and values.

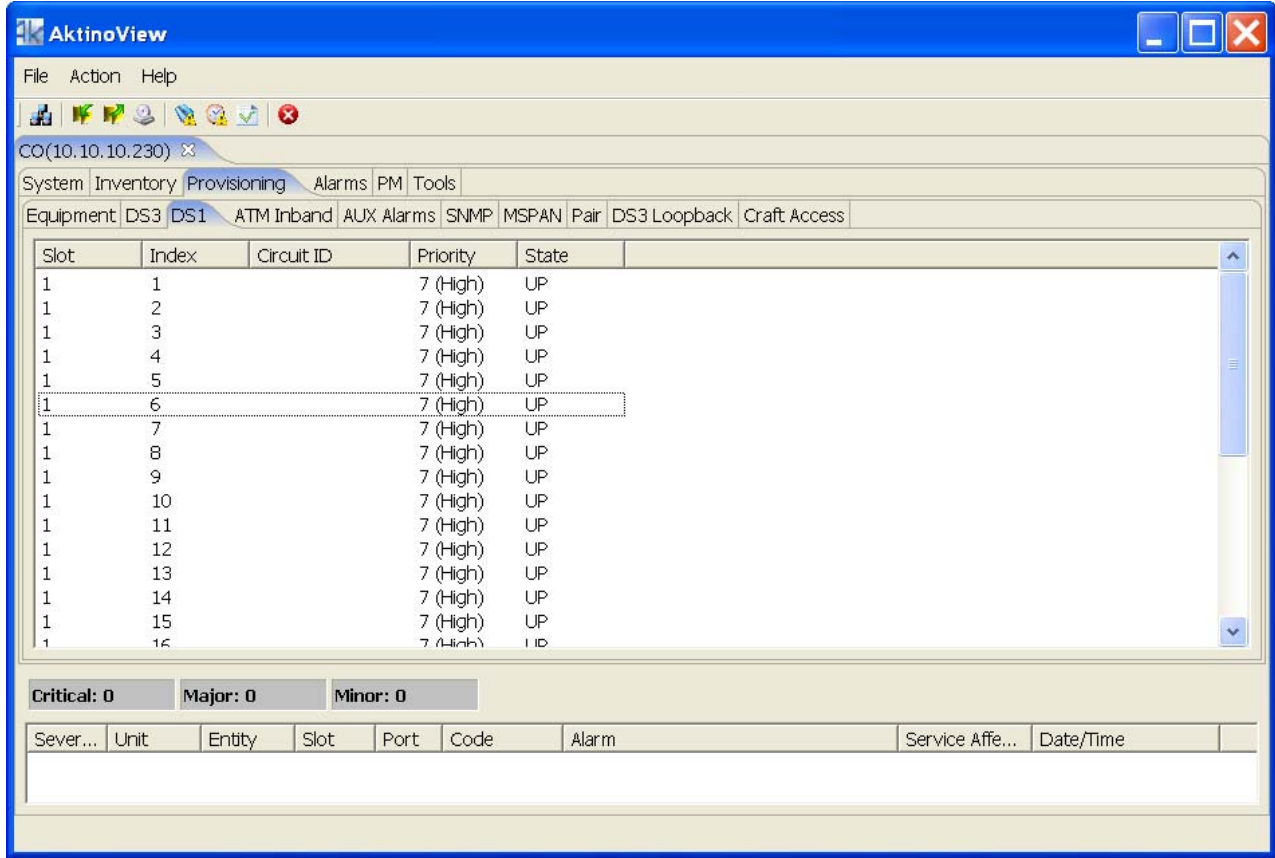
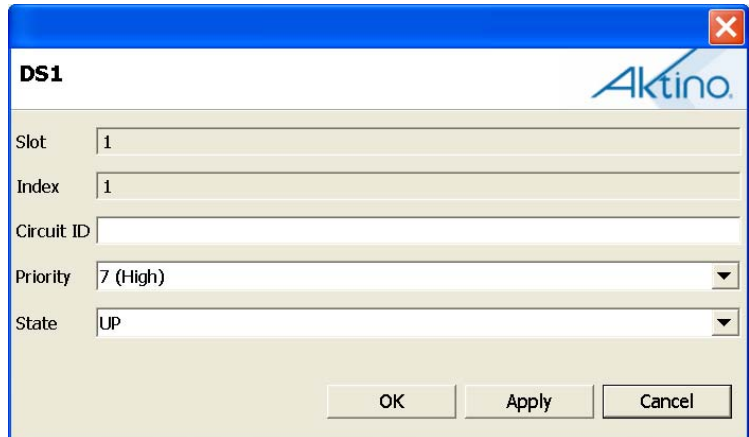

Table 7 DS1 Provisioning Parameters

<u>Parameter</u>	<u>Values</u>
Circuit ID	Circuit ID of DS1
Priority	0[Low] through 7[High] When system needs to downshift the MSPAN rate during adverse conditions (e.g. a pair failed), the priority parameter determines the order of DS1's dropped
State	DOWN- DS1 tributary is not transported UP- DS1 tributary is transported



Provisioning ATM Inband Management

Selecting the ATM Inband tab under Provisioning allows ATM Inband Management provisioning of the system. The DS3 Payload Type must be in an ATM mode allow setting this item. See Table 8 for parameters and values.

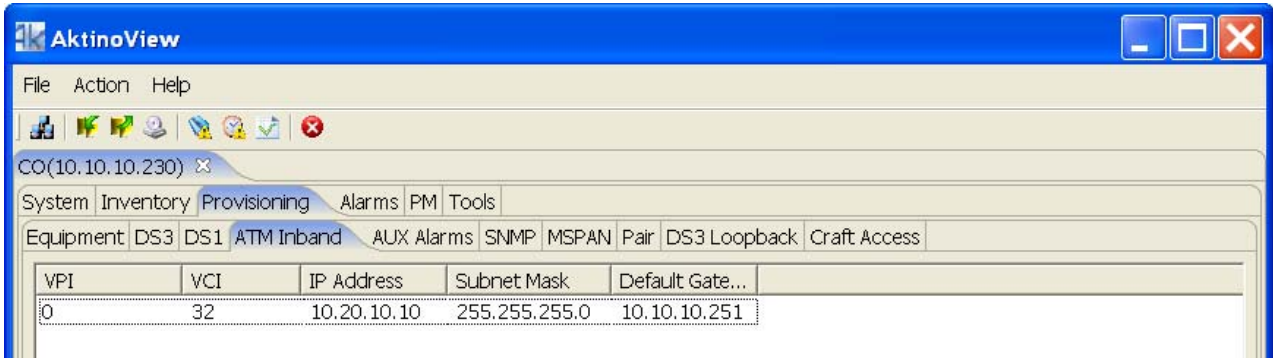
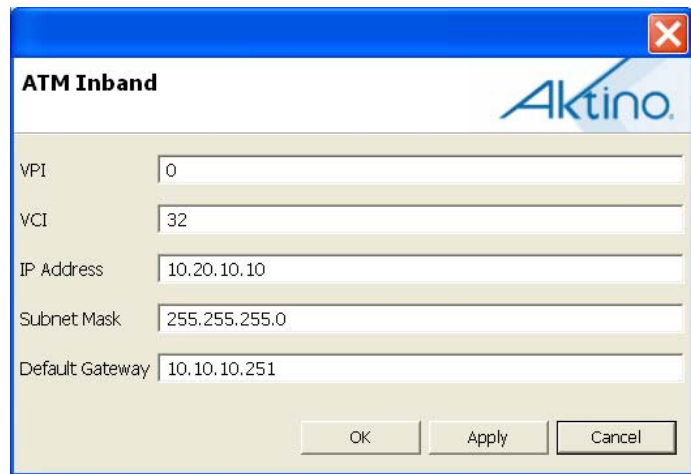

Table 8 ATM Inband Parameters

<u>Parameter</u>	<u>Values</u>
VPI	Virtual Path Identifier
VCI	Virtual Circuit Identifier
IP Address	IP address of the Aktino unit (must be in a different subnet vs. the local management port)
Subnet Mask	Subnet mask for the Aktino unit
Default Gateway	Gateway address for the Aktino unit



Provisioning AUX Alarms Screen

Selecting the AUX Alarms tab under Provisioning allows external alarm provisioning of the system. These parameters determine how the AUX1 and AUX2 input pins on the Aktino units react. Note that the alarm input pins are Normally Open (NO). Right click on the Index to bring up the Aux Alarm configuration popup. See Table 9 for parameters and values.

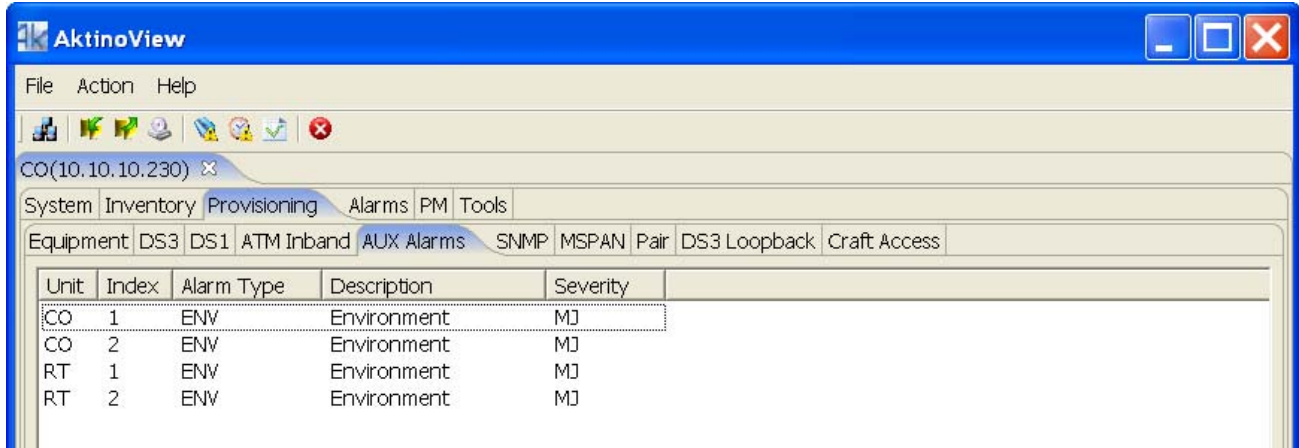
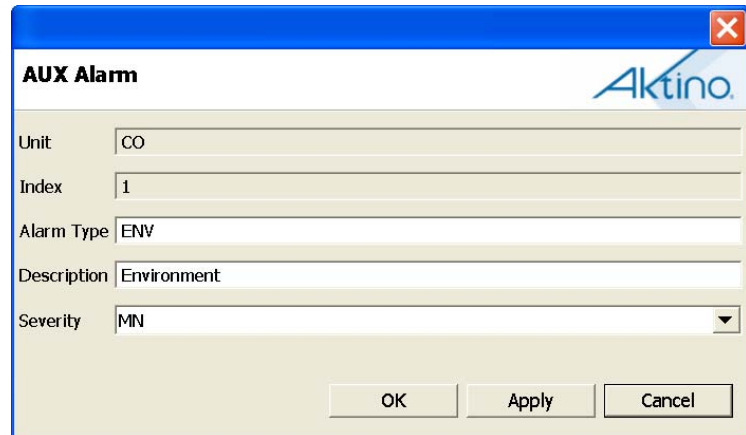

Table 9 AUX Alarm Parameters

<u>Parameter</u>	<u>Values</u>
Alarm Type	This value is reported as alarm type in the TL1 alarm message
Description	This value is reported as alarm description in the TL1 alarm message
Severity	Critical, Major, Minor



Provisioning SNMP Screen

Selecting the SNMP tab allows setting SNMP receiver parameters. Right click on the Index to bring up the Aux Alarm configuration popup. See Table 10 below for details.

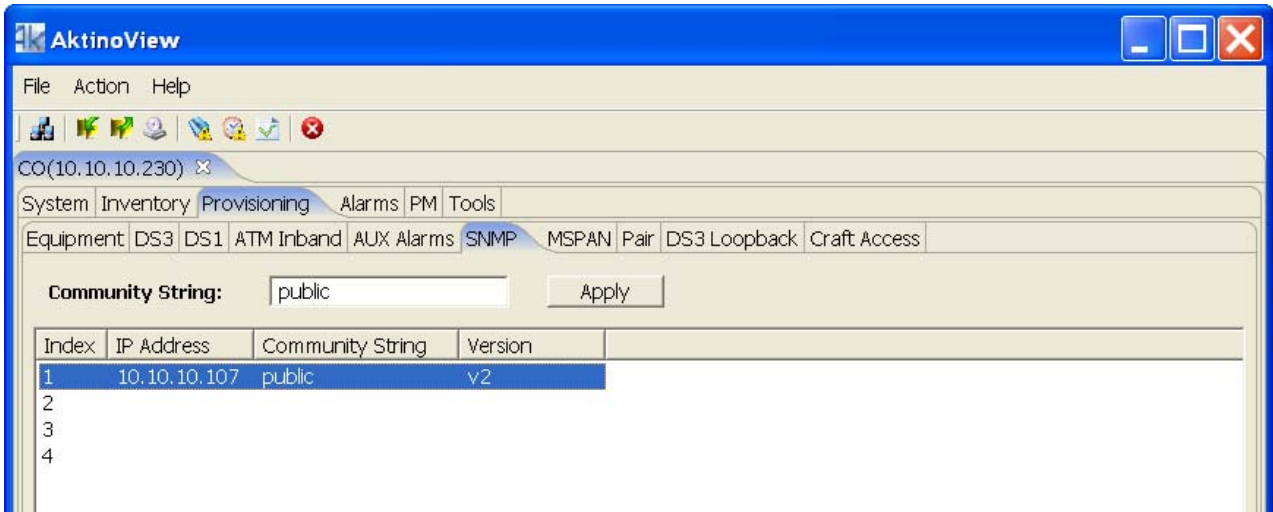

Table 10 SNMP Parameters

<u>Parameter</u>	<u>Values</u>
IP Address	SNMP Trap receiver IP Address
Community String	SNMP defined community string
Version	Version- SNMP V1 or V2



Provisioning MSPAN Screen

Selecting the MSPAN tab under Provisioning allows MSPAN provisioning of the system. Right click on the Parameters line to bring up the either the General or Advanced Parameters. See Table 11 and Table 12 for parameters and values.

The screenshot shows the AktinoView software interface. The main window displays the MSPAN provisioning screen. The 'General Parameters' table is as follows:

Slot	Circuit ID	Mode	Rate Upstream...	Rate Downstream...	Line Powering	SNR Margi...	Margin Threshold...	Reserve Pairs	PSD Mask	State
1		Symmetric	44224	44224	-185V	5	3	0	AUTO Select	UP

The 'Advanced Parameters' table is as follows:

Slot	Reed-Solomon ...	Reed-Solomon ...	Latency Upstre...	Latency Downs...	Impulse Prot. U...	Impulse Prot. D...	Power Back-Off...	Power Back-Off...
1	6.60	6.60	16	16	500	500	AUTO	AUTO

At the bottom of the window, there are status indicators: Critical: 0, Major: 0, Minor: 0. Below these are several empty table rows with columns: Sever..., Unit, Entity, Slot, Port, Code, Alarm, Service Affe..., Date/Time.

The 'MSPAN - General Parameters' dialog box contains the following parameters:

- Slot: 1
- Circuit ID: (empty)
- Mode: Symmetric
- MSPAN Rate (kbps): 44224
- Rate Upstream (kbps): 44224
- Rate Downstream (kbps): 44224
- Line Powering: -185V
- SNR Margin (dB): 5
- Margin Threshold (dB): 3
- Reserve Pairs: 0
- PSD Mask: AUTO Select
- State: UP

Buttons: OK, Apply, Cancel

Table 11 MSPAN Provisioning Parameters

<u>Parameter</u>	<u>Values</u>
Circuit ID	Circuit ID, max 48 characters
MSPAN Mode (R2.10 or higher)	Symmetric Asymmetric (Valid only when Payload Type is ATM or Scrambled ATM)
MSPAN Rate Rate Upstream Rate Downstream	0 to 44224 Kbps (Valid if Payload Type is ATM or Scrambled ATM. MSPAN Rate for Clear Channel Payload Type is set to 44736 Kbps. MSPAN Rate for Channelized DS3 Payload Type is set by the number of DS1's set to UP State in the DS1 Provisioning tab.)
Line Powering	OFF- RT is local powered -135v -185v
SNR Margin [dB]	0 to 18dB. Set value is desired MSPAN margin
Margin Threshold [dB]	0 to 18 (≤ SNR Margin) If MSPAN margin falls below Margin Threshold value, an alarm is set
Reserve Pairs	1 to 13
PSD Mask	Auto-Selects mask automatically Select M1, M2, M3, M4, M5 RT Deployment M1 RT Deployment M2 Upstream 276khz Repeater Span1: M1 Repeater Span2: M1, M2, M3 Exclude M1 (6kft mask) Exclude M1, M2 (6/9kft masks) Exclude M1, M2, M3 (6/9/11.5kft masks) Exclude M1, M2, M3, M4 (6/9/11.5/13kft masks)
State	UP- MSPAN port is in service DOWN- MSPAN port is out of service

Table 12 MSPAN Advanced Parameters

<u>Parameter</u>	<u>Values</u>
Upstream/Downstream Reed-Solomon Overhead [%]	Calculated Reed-Solomon Overhead percentage $RS\% = 2 * INP / Latency$
Upstream/Downstream Interleaver Latency [msec]	0, 2, 4, 6, 8, 12, 16, 20 msec Latency of the PHY
Upstream/Downstream Impulse Noise Protection (INP) [usec]	50, 125, 250, 500, 750, 1000 usec Length of noise protection
Upstream/Downstream Power Back-Off [dB]	Auto, -3 to 16 dB

MSPAN - Advanced Parameters

Slot: 1

Reed-Solomon Upstream: 6.60

Reed-Solomon Downstream: 6.60

Latency Upstream: 4

Latency Downstream: 4

Impulse Prot. Upstream (us): 125

Impulse Prot. Downstream (us): 125

Power Back-Off Upstream (dB): AUTO

Power Back-Off Downstream (dB): AUTO

Buttons: OK, Apply, Cancel

Provisioning Pair Screen

Selecting the PAIR tab under Provisioning allows PAIR provisioning of the system. Right click on the Pair to bring up the Pair configuration popup. See Table 13 for parameters and values.

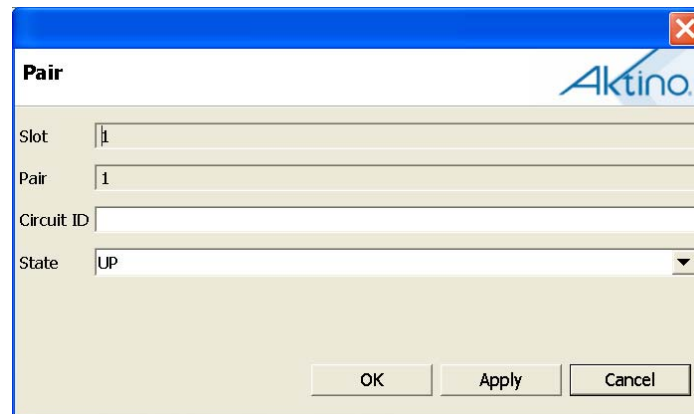
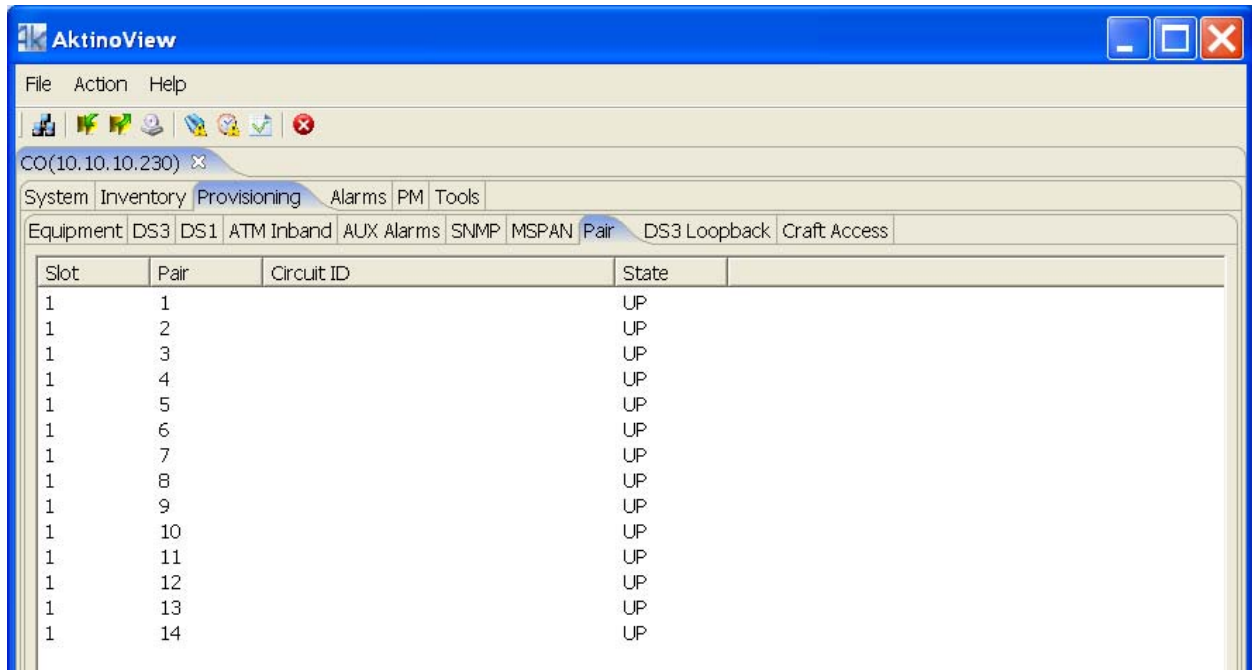
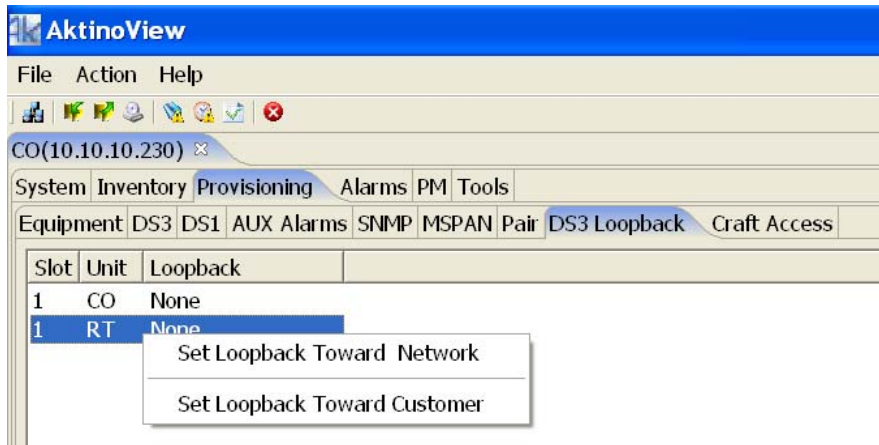

Table 13 PAIR Provisioning Parameters

<u>Parameter</u>	<u>Values</u>
Circuit ID	Circuit ID of each pair
State	UP- Puts Pair into service DOWN- Removes Pair from service

Provisioning DS3 Loopback Screen

Selecting the DS3 Loopback tab under Provisioning allows loopbacks of the system. Right click on the Unit to bring up the Loopback popup as shown below. When a loopback is set, right clicking on the Unit will provide release loopback.



Note the Loopback alarm in the alarm status window below, and the loopback arrow on the System status screen.

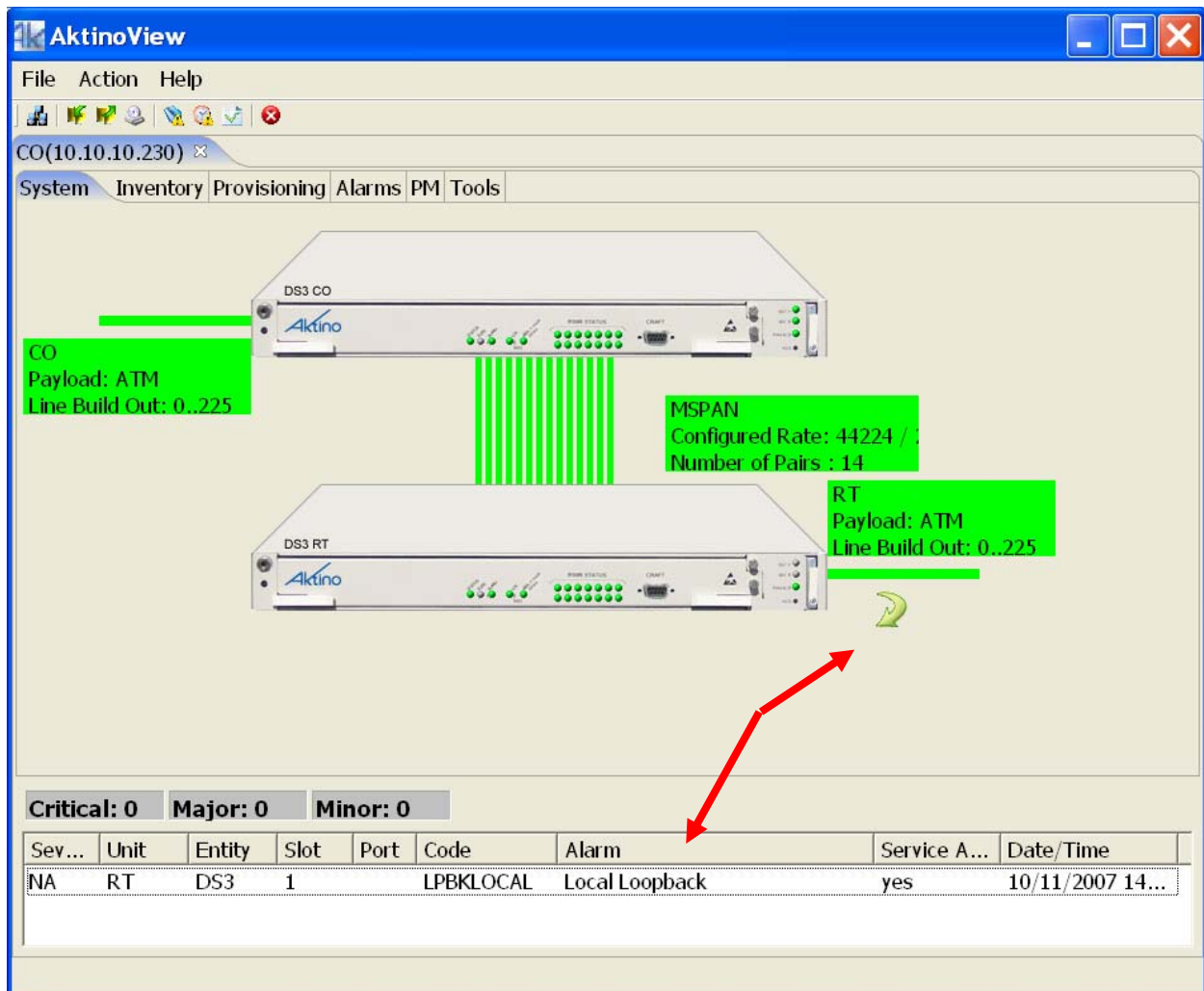

Provisioning Craft Access Screen

Selecting the Craft Access tab under Provisioning allows management administration. Click on Create to bring up the Craft Access popup as shown below.

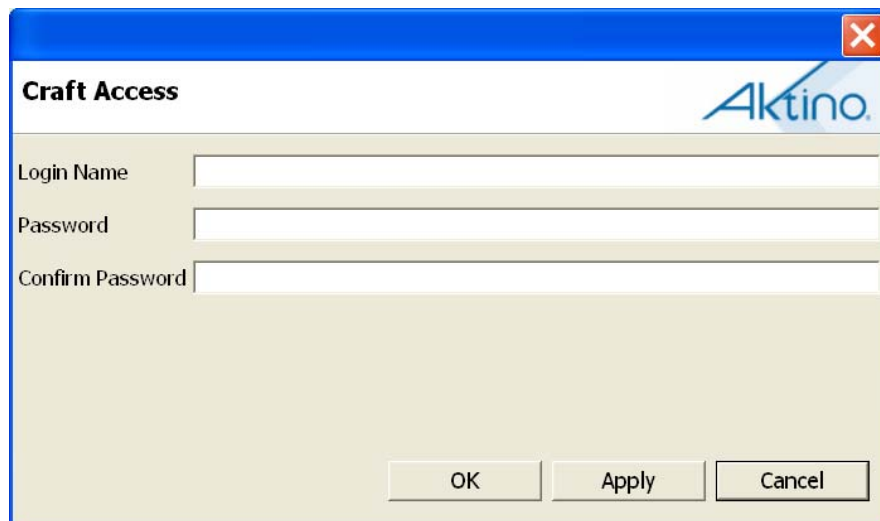
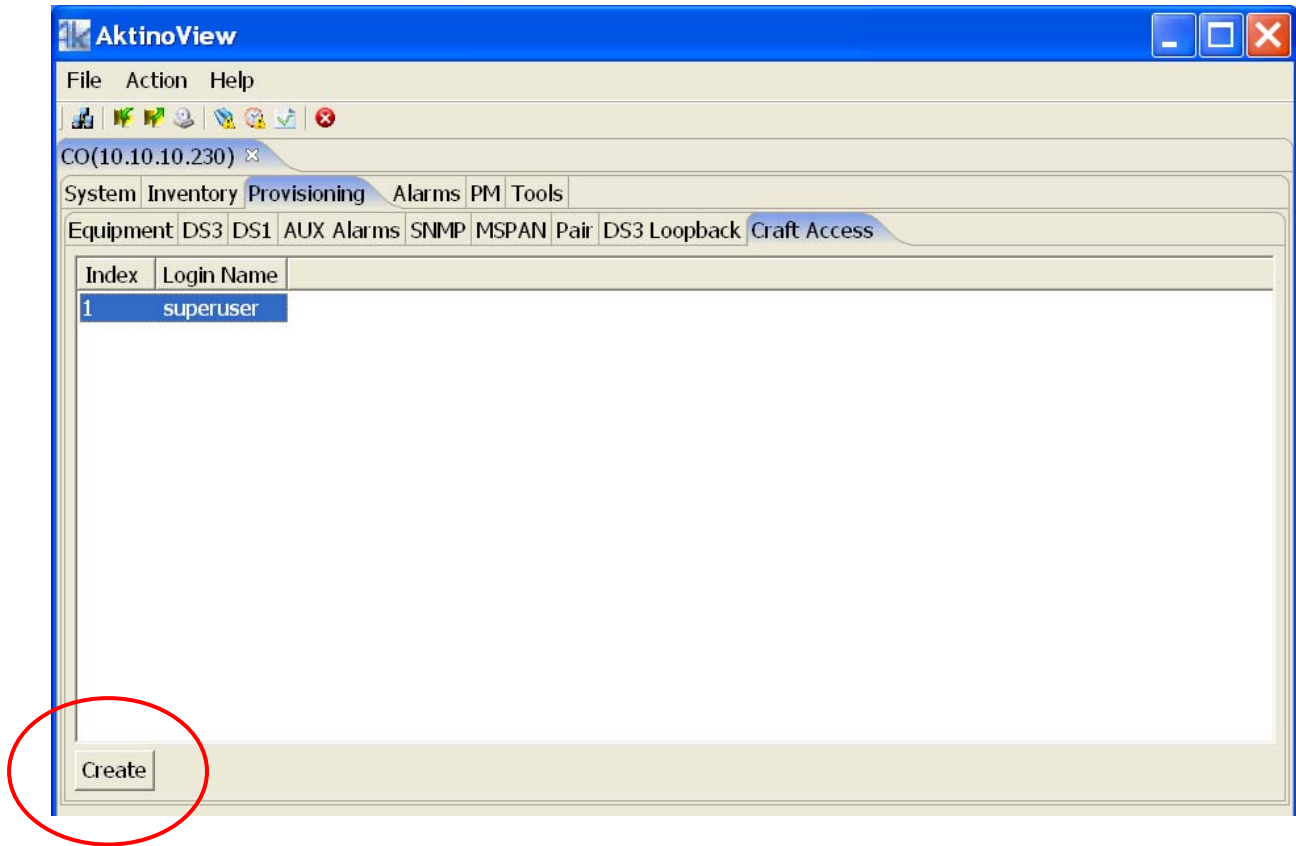

Alarms

Alarms CO and RT Alarm Log

The Alarm Log is a list of alarms that have occurred on the CO (CO tab) and on the RT (RT tab). Select Refresh to update screen. Any of the column headings can be clicked to sort by that column. See Table 14 for descriptions of columns.

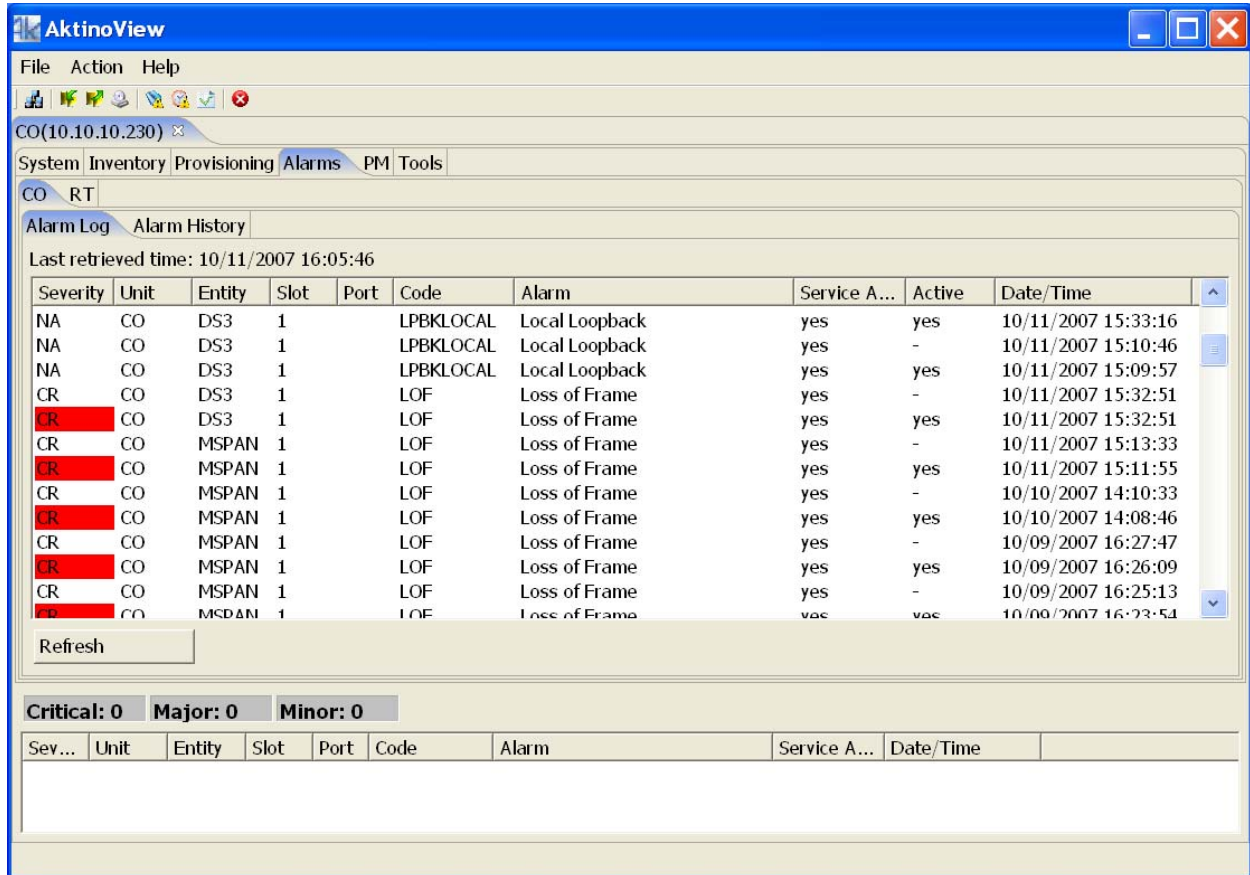

Table 14 Alarm Log

Parameter	Definition
Severity	Critical/Major/Minor state of the Alarm. Color highlighted indicates alarm active; no highlight indicates the alarm has cleared.
Unit	CO or RT
Entity	DS3, MSPAN, COM, or PAIR
Port	Pair number
Code	Alarm code

Parameter	Definition
Alarm	Alarm description
Service Affecting	“yes” indicates that the alarm is service affecting
Active	Indicates if alarm is active
Date/Time	Date/time of the event

Alarms CO and RT Alarm History

The Alarm History is a summary of alarms that have occurred on the CO (CO tab) and on the RT (RT tab). Select Refresh to update screen. Any of the column headings can be clicked to sort by that column. See Table 15 for description of columns.

Severity	Unit	Entity	Slot	Port	Code	Alarm	Service Affe...	First Time	Last Time	Occurrences
CR	CO	DS3	1		LOS	Loss of Signal	yes	09/14/2006 20...	10/11/2007 15...	18
NA	CO	DS3	1		LPBKLINE	Line Loopback	yes	09/14/2006 20...	10/11/2007 15...	12
NA	CO	DS3	1		LPBKLOCAL	Local Loopback	yes	09/14/2006 21...	10/11/2007 15...	6
CR	CO	DS3	1		LOF	Loss of Frame	yes	01/29/2007 08...	10/11/2007 15...	2
CR	CO	MSPAN	1		LOF	Loss of Frame	yes	09/05/2006 17...	10/11/2007 15...	2200
CR	CO	MSPAN	1		LOS	Loss of Signal	yes	09/05/2006 17...	10/11/2007 15...	2197
MJ	CO	MSPAN	1		RATE	MSPAN Capacity Under Config...	yes	09/14/2006 05...	10/09/2007 16...	32
MN	CO	MSPAN	1		RESERVE	Reserve Pairs Less than Confi...	-	09/21/2006 23...	10/09/2007 14...	6
MN	CO	MSPAN	1		MARGIN	SNR Margin Below Configured...	yes	01/19/2007 16...	10/09/2007 10...	76
CR	CO	COM			SYSTEM_...	System Reboot	yes	09/05/2006 18...	10/09/2007 09...	17
MN	CO	PAIR	1	11	LOS	Loss of Signal	-	09/22/2006 00...	10/06/2007 21...	2
MN	CO	PAIR	1	10	LOS	Loss of Signal	-	09/14/2006 05...	10/06/2007 21...	3
MN	CO	PAIR	1	9	LOS	Loss of Signal	-	09/14/2006 05...	10/06/2007 21...	2

Refresh

Critical: 0 Major: 0 Minor: 0

Table 15 Alarm History

Parameter	Definition
Severity	Critical/Major/Minor state of the Alarm. Color highlighted indicates alarm active, no highlight indicates the alarm has cleared.
Unit	CO or RT
Entity	DS3, MSPAN, COM, or PAIR
Port	Pair number
Code	Alarm code
Alarm	Alarm description

Parameter	Definition
Service Affecting	“yes” indicates that the alarm is service affecting
First Time	Date/time of first occurrence of the event
Last Time	Date/time of last occurrence of the event
Occurrences	The number of times the alarm has occurred

Performance Monitoring

PM DS3 Performance Monitoring

DS3 performance monitoring shows the errors coming INTO the CO (CO tab) DS3 port and INTO the RT (RT tab) DS3 port. Ninety six fifteen minute time period bins and seven 24 hour time period bins display the DS3's performance monitoring. Select Refresh to update screen. See Table 16 for definitions of the PM values.

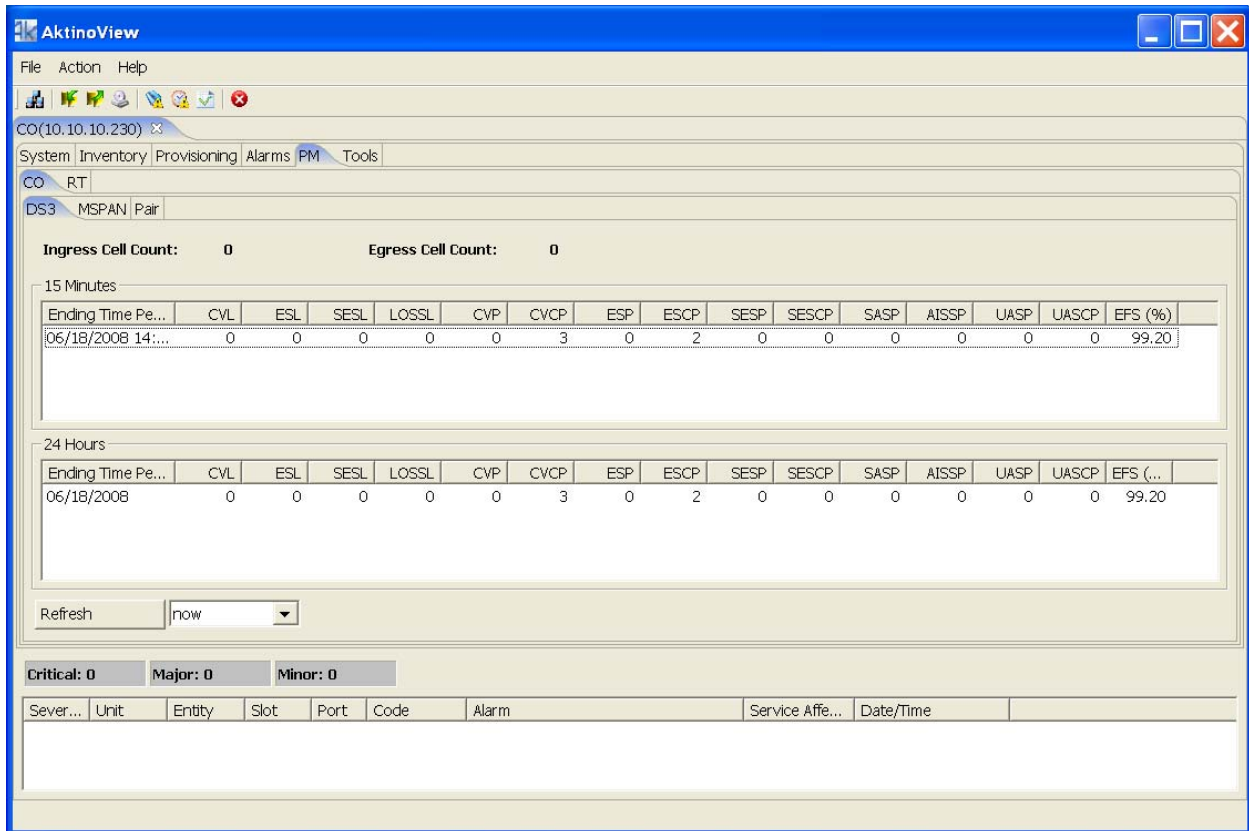

Table 16 DS3 Performance Monitoring Parameters

<u>Parameter</u>	<u>Definition</u>
Ingress Cell Count	Number of ATM cells flowing into either CO or RT Aktino DS3 port (ATM modes only)
Egress Cell Count	Number of ATM cells flowing out of either CO or RT Aktino DS3 port (ATM modes only)
CVL	Line Code Violations
ESL	Line Errored Seconds
SESL	Line Severely Errored Seconds
LOSSL	Line Loss of Signal Seconds
CVP	Path Code Violations
CVCP	Path Code Violations CP-bit Parity

<u>Parameter</u>	<u>Definition</u>
ESP	Path Errored Seconds
ESCP	Path Errored Seconds CP-bit Parity
SESP	Path Severely Errored Seconds
SESCP	Path Severely Errored Seconds CP-bit Parity
SASP	SEF/AIS Second C-bit Parity
AISSP	Path Alarm Indication Status Seconds
UASP	Path UnAvailable Seconds
EFS%	Error Free Seconds %

PM CO and RT MSPAN Performance Monitoring

The MultiPair Span Performance Monitoring (PM) information is displayed on the MSPAN tab. PM is available for either the CO (CO tab) or RT (RT tab) side. The display shows current values at the top of the window. Ninety six fifteen minute time period bins and seven 24 hour time period bins display the MultiPair Span's performance monitoring. Select Refresh to update screen. See Table 17 for definitions of the PM values.

The screenshot shows the AktinoView application window. The main display area shows the following performance metrics:

- Capacity (Kbps): 50552
- Rate (Kbps): 43232
- Margin (dB): 7.53
- State: DATA
- PSD Mask: M2
- TX Utilization (%):
- RX Utilization (%):

Below these metrics are two tables showing performance data for different time periods:

15 Minutes

Ending Time Period	CRC	ES	SES	UAS	Min Capacity	Max Capacity	Min Rate	Max Rate	Min Margin	Max Margin	TX Util (%)	RX Util (%)	EFS (%)
06/18/2008 14:24	0	0	0	186	0	50716	0	43232	0.00	8.09			67.48

24 Hours

Ending Time Period	CRC	ES	SES	UAS	Min Capacity	Max Capacity	Min Rate	Max Rate	Min Margin	Max Margin	TX Util (%)	RX Util (%)	EFS (%)
06/18/2008	0	0	0	186	0	50716	0	43232	0.00	8.09			67.48

At the bottom of the interface, there is a 'Refresh' button, a dropdown menu set to 'now', and a 'Slot' dropdown menu set to '1'. Below this, a status bar shows 'Critical: 0', 'Major: 0', and 'Minor: 0'. At the very bottom, there is a table with columns: Sever..., Unit, Entity, Slot, Port, Code, Alarm, Service Affe..., and Date/Time.

Table 17 MSPAN PM Parameters

Parameter	Definition
Capacity [Kbps]	Displays the current MSPAN capacity at the provisioned System Margin value
Rate [Kbps]	Displays the current actual MSPAN rate
Margin [db]	Displays the current MSPAN margin value
State	TRAINING- MSPAN is training up, no data is being transported DATA- MSPAN is up, data is being transported
PSD Mask	Selected PSD mask
Tx Utilization [%]	% of ATM frames being transmitted in the MSPAN vs. MSPAN provisioned rate
Rx Utilization [%]	% of ATM frames being received from the MSPAN vs. MSPAN provisioned rate

Table 16 MSPAN PM Parameters (continued)

Parameter	Abbreviation	Units	Definition
CRC	CRC error	n/a	Uncorrectable error on the MSPAN. There should be corresponding ES on pairs.
ES	Error Seconds	Seconds	One or more crcs in a second
SES	Severely Error Seconds	Seconds	44 or more crc in a second or MSPAN loss of signal (LOS) or MSPAN loss of frame (LOF)
UAS	Unavailable Seconds	Seconds	10 consecutive SES result in a UAS. The SES counter will get reset to 0 upon reaching 10 ses and the UAS counter will start at 10 seconds.
Min Capacity	Minimum Capacity	Kbps (Kilo bits per Sec)	Minimum capacity during a given 15 minute period
Max Capacity	Maximum Capacity	Kbps (Kilo bits per Sec)	Maximum capacity during a given 15 minute period
Min Rate	Minimum Rate	Kbps (Kilo bits per Sec)	Minimum rate during a given 15 minute period
Max Rate	Maximum Rate	Kbps (Kilo bits per Sec)	Maximum rate during a given 15 minute period
Min Margin	Minimum Margin	dB	Minimum margin during a given 15 minute period
Max Margin	Margin Maximum	dB	Maximum margin during a given 15 minute period
Tx Util (%)	Transmit Utilization	%	Actual Data payload as a percentage of the total available TX MSPAN rate. This value is only reported for Ethernet and DS3 ATM applications.
Rx Util (%)	Receive Utilization	%	Actual Data payload as a percentage of the total available RX MSPAN rate. This value is only reported for Ethernet and DS3 ATM applications.
EFS (%)	Error Free Seconds	%	EFS is the percentage of error free seconds over either a 15 minute or 24 hour bin.

PM CO and RT Pair Summary Performance Monitoring

A summary of all pairs for either CO (CO tab) or RT (RT tab) side can be displayed by clicking Summary under PM Pair. Select Refresh to update screen. See Table 18 for definitions of the pair summary screen.

Time Period	Slot	Unit	Pair	Remote Pair	Capacity	Rate	Mar...	Voltage	Line Current	Ground Current
06/18/2008 14:30:01	1	CO	1	1	3408	3144	7.48	187.26	29.06	0.50
06/18/2008 14:30:01	1	CO	2	2	3432	3180	7.55	187.26	28.55	0.50
06/18/2008 14:30:02	1	CO	3	3	3560	3300	7.53	187.26	30.08	0.50
06/18/2008 14:30:02	1	CO	4	4	3652	3412	7.55	187.26	30.08	0.50
06/18/2008 14:30:03	1	CO	5	5	3608	3356	7.52	187.26	30.08	0.50
06/18/2008 14:30:03	1	CO	6	6	3600	3356	7.58	187.26	30.08	0.50
06/18/2008 14:30:04	1	CO	7	7	3628	3384	7.36	187.26	30.08	0.50
06/18/2008 14:30:04	1	CO	8	8	3684	3436	7.53	187.26	30.08	0.50
06/18/2008 14:30:05	1	CO	9	9	3588	3348	7.44	187.26	30.08	0.50
06/18/2008 14:30:05	1	CO	10	10	3804	3564	7.59	187.26	30.08	0.50
06/18/2008 14:30:06	1	CO	11	11	3612	3368	7.50	187.26	30.08	0.50
06/18/2008 14:30:06	1	CO	12	12	3824	3580	7.47	187.26	30.08	0.50
06/18/2008 14:30:07	1	CO	13	13	3444	3204	7.41	187.26	30.08	0.50
06/18/2008 14:30:07	1	CO	14	14	3696	3448	7.58	187.26	30.08	0.50

Table 18 Summary PM Monitoring Parameters

Parameter	Definition
Remote Pair	Remote unit's pair number that is attached to the CO pair number
Capacity	Displays the pair's capacity at the provisioned System Margin value
Rate	Displays the current actual pair rate
Margin	Displays the pair's margin value
Voltage	Displays the detected voltage sealing current or line powering voltage
Current	Displays the detected current
Ground current	Displays the current to ground (Acceptable range is 0 to 1.0mA)

PM CO and RT Pair Current 15 Minutes and 24 Hours Performance Monitoring

The current fifteen minute time period and current 24 hour time period pair performance monitoring is display under PM CO (CO tab) or RT (RT tab) Current 15 Minutes and Current 24 Hours tabs. Select Refresh to update screen. See Table 19 for definitions of the current pair screen.

Time Period	Slot	Unit	Pair	CS	ES	SES	UAS	Min Capacity	Max Capacity	Min Rate	Max Rate	Min Margin	Max Mar...	EFS (%)
06/18/2008 14:31:05	1	CO	1	0	0	0	0	3404	3420	3144	3144	7.42	7.55	100.00
06/18/2008 14:31:05	1	CO	2	0	0	0	0	3424	3440	3172	3184	7.48	7.73	100.00
06/18/2008 14:31:06	1	CO	3	0	0	0	0	3552	3568	3296	3304	7.45	7.69	100.00
06/18/2008 14:31:06	1	CO	4	0	0	0	0	3652	3668	3412	3412	7.55	7.67	100.00
06/18/2008 14:31:07	1	CO	5	0	0	0	0	3596	3608	3352	3360	7.36	7.53	100.00
06/18/2008 14:31:07	1	CO	6	0	0	0	0	3592	3600	3352	3356	7.44	7.58	100.00
06/18/2008 14:31:08	1	CO	7	0	0	0	0	3624	3640	3380	3384	7.33	7.50	100.00
06/18/2008 14:31:08	1	CO	8	0	0	0	0	3676	3688	3436	3436	7.47	7.61	100.00
06/18/2008 14:31:09	1	CO	9	0	0	0	0	3580	3596	3340	3352	7.34	7.56	100.00
06/18/2008 14:31:09	1	CO	10	0	0	0	0	3792	3808	3560	3564	7.53	7.67	100.00
06/18/2008 14:31:10	1	CO	11	0	0	0	0	3600	3612	3368	3368	7.39	7.52	100.00
06/18/2008 14:31:10	1	CO	12	0	0	0	0	3812	3828	3580	3580	7.39	7.53	100.00
06/18/2008 14:31:11	1	CO	13	0	0	0	0	3436	3456	3200	3208	7.34	7.50	100.00
06/18/2008 14:31:11	1	CO	14	0	0	0	0	3680	3700	3448	3448	7.44	7.61	100.00

Table 19 Current 15 Minutes & 24 Hours Pair PM

Parameter	Definition
CS	Corrected Seconds- Number of seconds in which one or more errors were corrected by error correction algorithms.
ES	Errored Seconds
SES	Severely Errored Seconds
UAS	UnAvailable Seconds
Min Capacity	Minimum Capacity (kbps)
Max Capacity	Maximum Capacity (kbps)
Min Rate	Minimum Rate (kbps)
Max Rate	Maximum Rate (kbps)
Min Margin	Minimum Margin (db)
Max Margin	Maximum Margin (db)
EFS%	Error Free Seconds %

PM CO and RT Pair History Performance Monitoring

Ninety six fifteen minute time period bins and seven 24 hour time period bins display the history of the pair's performance monitoring. Select Refresh to update screen. Select the Pair by the pull down menu indicated. See Table 19 above for definitions of the current pair screen.

The screenshot shows the AktinoView application window. The main content area displays performance metrics for a CO/RT pair. The 'Summary' tab is active, showing the following data:

Capacity (Kbps):	3436	Rate (Kbps):	3180	Margin (dB):	7.53
Line Voltage (V):	187.26	Current (mAmp):	28.55	Ground Current (mAmp):	0.5
State:	ACTIVE	Remote Pair:	2	Attenuation (dB):	37.45

Below the summary, there are two history tables:

15 Minutes

Ending Time Per...	CS	ES	SES	UAS	Min Capacity	Max Capacity	Min Rate	Max Rate	Min Mar...	Max Ma...	EFS (...)
06/18/2008 14:35	0	0	0	0	3416	3444	3172	3184	7.45	7.73	100.00
06/18/2008 14:30	2	0	0	187	0	3460	0	3200	0.00	8.27	79.01

24 Hours

Ending Time Pe...	CS	ES	SES	UAS	Min Capacity	Max Capa...	Min Rate	Max Rate	Min Mar...	Max Ma...	EFS (...)
06/18/2008	2	0	0	187	0	3460	0	3200	0.00	8.27	84.88

At the bottom of the interface, there is a 'Refresh' button, a 'now' dropdown, and two dropdown menus for 'Slot' (set to 1) and 'Pair' (set to 2). A callout box points to the 'Slot' dropdown with the text: 'Select slot, fresh frequency and pair'.

Tools & Menu bar

The top of the AktinoView window contains a menu bar with drop down menus. In addition, the same functionality is available on the Tools tab.

Right clicking on a slot number under the Tools tab brings up the indicated menu.

- Software Upgrade- CO Only upgrades the CO unit only
- Software Upgrade- RT only upgrades the RT unit only. This is available only when connected to the RT directly.
- Revert Software and Reboot takes the Standby Version shown and makes it the Active Version, then reboots
- Reboot will reboot the line card
- Reset PM, Logs, or PM/Logs will zero the Performance Monitoring on the card
- Export logs creates a file with the units system logs (CO only)
- RT Ground Test runs a test to determine if the Remote Unit is chassis grounded (RT only)

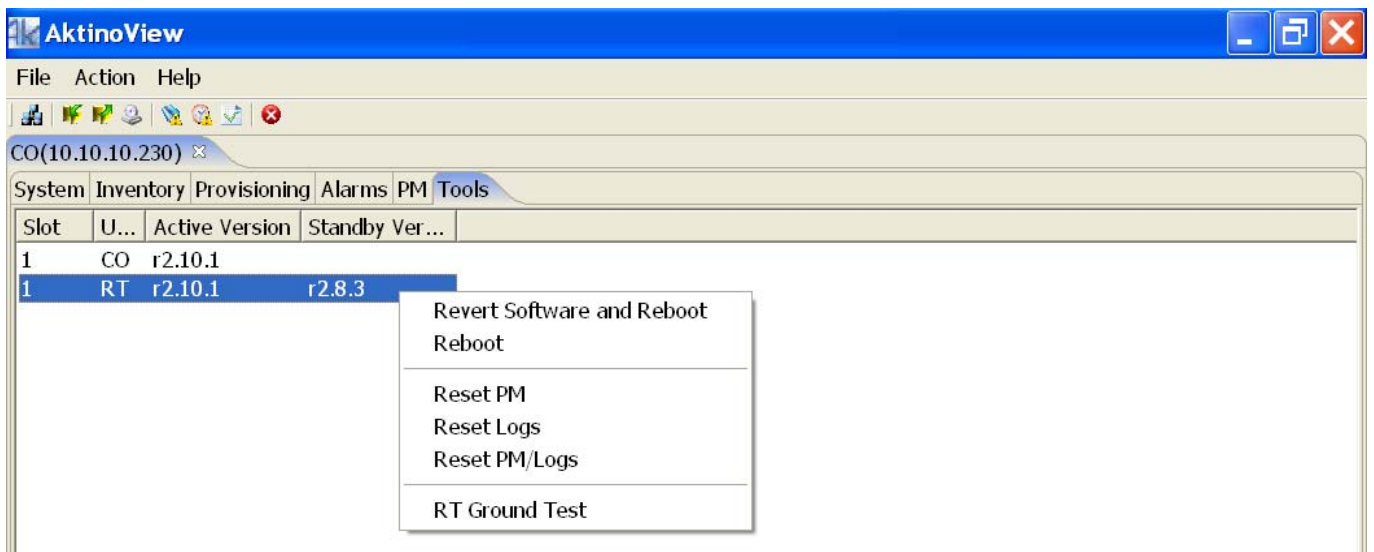
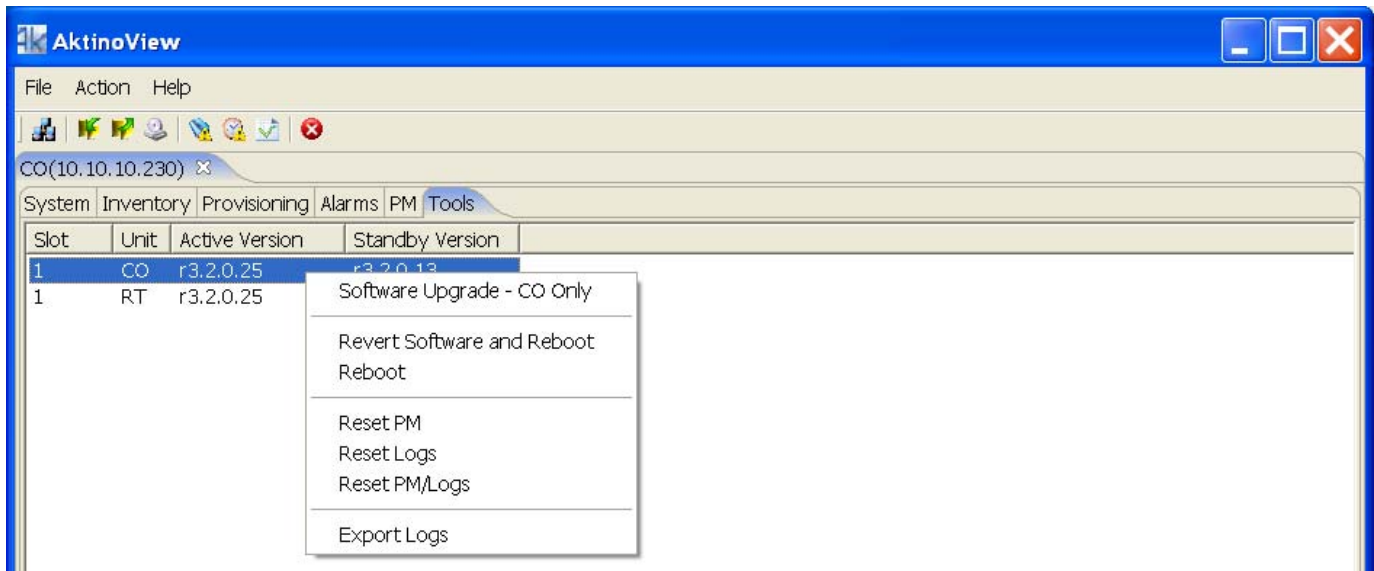

File, then Connect to... allows connection to other Aktino systems.

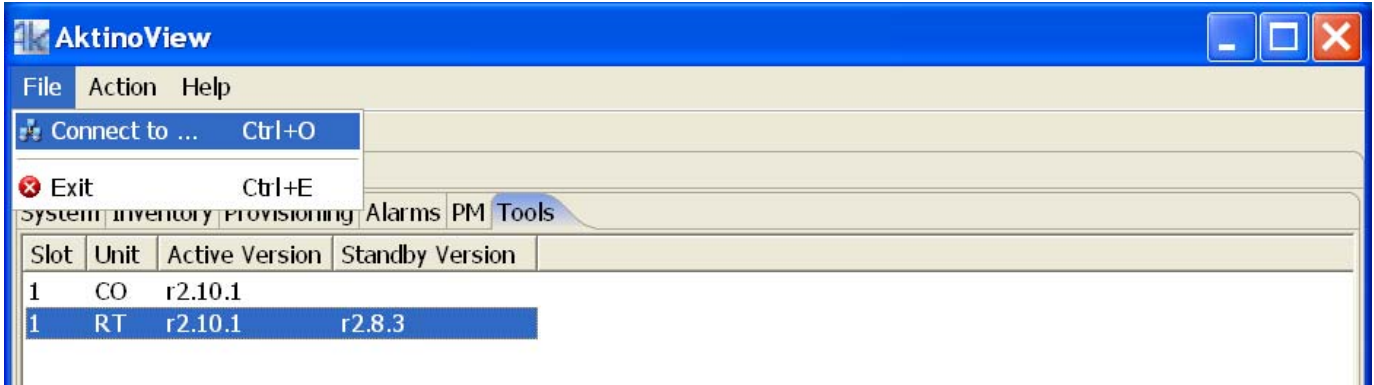

The Action Menu allows System Backup and Restore. This saves and restores the systems settings. Alarm log, alarm history, and Performance Monitoring (PM) can be exported using the Action pulldown as shown below. The output is in comma separated values Excel spreadsheet format.

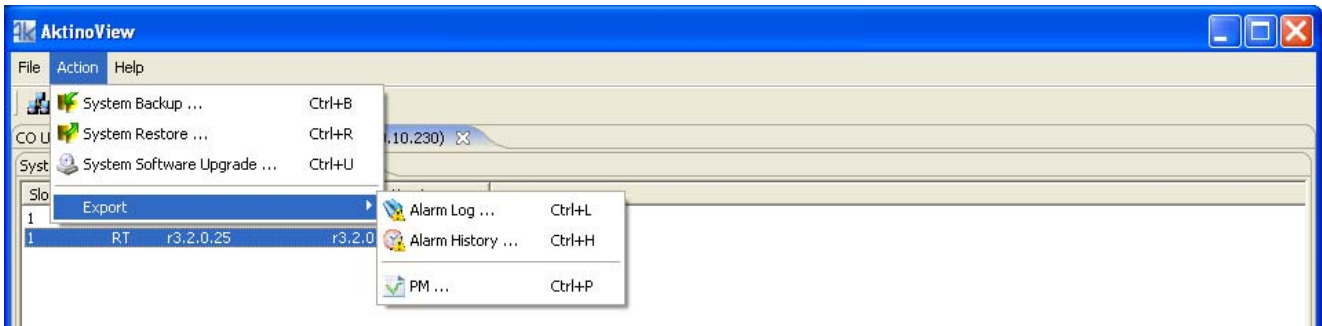

This popup appears when System Software Upgrade is selected from the Action Menu (shown below).

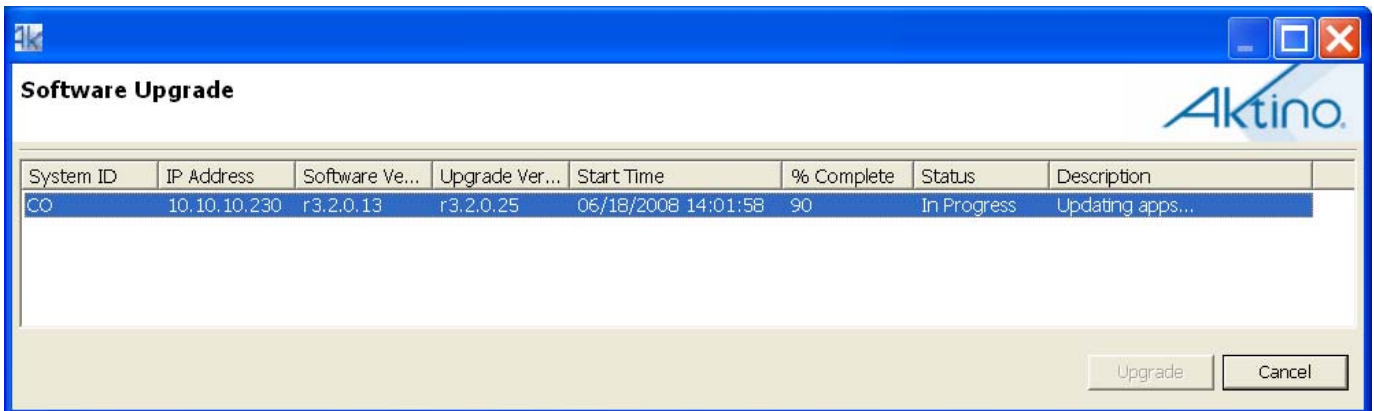

AK3000 Technical Specifications

System

- Bandwidth: FDS3 to Full DS3 (44.736 Mbps)
 - Full DS3 using only 12 pairs at CSA with full disturbers
- System Latency: 2 ms
- Resiliency: Carrier grade automatic pair failure protection
- BER: 10^{-12}
- Timing: Internal or Line

Interfaces

DS3

- Number of ports: 1 per card
- Connector: BNC
- Line rate: 44.736 Mbps ± 20 ppm
- Line code: B3ZS
- Line impedance: $75\Omega \pm 5\Omega$
- Jitter generation: ≤ 0.3 UI rms
- Line Buildout: 0 to 225, 226 to 450 ft.
- Framing: C-bit parity or M13
- Payload mode: Clear channel, ATM, Channelized
- Compliance: GR-499, T1.102, T1.107, T1.404

Outside Plant Pairs

- Technology: MIMO on DMT
- Number of pairs: 2-14
- Connector: 50-pin Telco
- Sealing current: Meets G991.2
- Compliance: T1.417 (Spectral)

Management interfaces

- Craft EIA-232 DB9
- Modem EIA-232 DB9
- 10/100BaseT RJ45

Electrical Specifications

- CO Unit
 - Power input: -42 to -56.7 Vdc
 - Max heat dissipation: 55-65 watts
- RT Unit
 - Line powered by CO unit or
 - Local power input: -42 to -56.7 Vdc
 - Max heat dissipation: 55 watts

Regulatory Approval

- NEBS Level 3
- UL60950
- FCC Part 15 Class A

Environmental

- Operating temperature: -40 to +65 deg C
- Storage temperature: -40 to +70 deg C
- Relative humidity: Up to 95%, non-condensing

Mechanical

- Chassis Dimensions: 1.75" high (1RU) x 17.1" wide x 12.0" deep
- Weight: Approximately 11 pounds

Alarm contacts

- Critical, Major, Minor, SysID
- Visual, Audio, Alarm CutOff Pushbutton
- AUX Input Alarms (2 inputs)

Front Panel Indicators

- Alarm, DS3 Status, System Status, Fuse
- MSPAN and Outside Plant Pair Status

Network Management

- TL1 (LFACS/TIRKS/NMA OSMINE)
- AktinoView GUI
- Aktino EMS

Warranty and Customer Service

Aktino will replace or repair this product within the warranty period if it does not meet its published specifications or fails while in service. Warranty information can be found in your Aktino customer web portal

www.aktino.com/Support/Customer_Login.aspx.

Aktino Sales Pricing/Availability:

949-258-0545

Aktino Technical Support

Pre-Sales Applications/Post-Sales Technical

Assistance: 949-258-0545

7 days/week, 24 hours/day

Aktino Repair

Return for Repair/Upgrade:

949-258-0545

Repair and Return Address

Contact Customer Service prior to returning equipment to Aktino.

Aktino, Inc.

18551 Von Karman Ave., Suite 201

Irvine, CA 92612

Equipment name	Description	CLEI Code
Kits		
AK3000C	CO DS3 Kit consisting of AK300C (Full DS3 at CSA, line powering) and AK100S shelf	Kit
AK3001C	CO DS3 Kit consisting of AK301C (Full DS3 at CSA) and AK100S shelf	Kit
AK3000R	RT DS3 Kit consisting of AK300R (Full DS3 at CSA) and AK100S shelf	Kit
Line cards		
AK300C	CO DS3 line card, Full DS3 at CSA, line powering	VAUIACMJ
AK301C	CO DS3 line card, Full DS3 at CSA	VAUIACNJ
AK300R	RT DS3 line card, Full DS3 at CSA	VAUIACPJ
Common Products		
AK100S	One slot 1RU high chassis with AK100F fan module	VAMB410F
AK100F	Fan module for AK100S chassis	VAEQAACB
AK100FL6	Filter 6 pack for AK100S chassis	NA
AK100B	Hinge Bracket for AK100S chassis	NA
AKRTPS	RT Power Supply (formerly AK100PSC)	NA
AK100TR	Tracer board	NA