



AIR Installation Guide

Publication Information

©2012 Positron Inc.

AIR Installation Guide

Publication date: April 2013

Printed in Canada

Published By

Positron Inc.

5101 Buchan Street, Suite 220

Montreal, Quebec, Canada

H402R9

Telephone US and Canada: 1-888-577-5254

International: 1-514-345-2220

Product names, other than Positron's, mentioned herein may be trademarks and/or registered trademarks their respective companies.

FCC Notification

The AK355RPT complies with part 15 Class A of the FCC Rules. Operation is subject to the following two conditions (1) This device may not cause harmful interference, and (2) this device must accept any interference received, including interference that may cause undesired operation.

Confidentiality Notice

The information contained in this document is the property of Positron Inc. Except as specifically authorized in writing by Positron Inc., the holder of this document: 1) shall keep all information contained herein confidential and shall protect same in whole or in part from the disclosure and dissemination to all third parties, and 2) shall use same for operating and maintenance purposes only.

Disclaimer Notice

Although Positron Inc. has made every effort to ensure the accuracy of the information contained herein, this document is subject to change.

CONTENTS

Chapter 1	4
AIR Series Overview	4
1.1 Introduction.....	5
Chapter 2	6
AK355RPT(RC)	6
2.1 AK355RPT(RC) Installation	7
2.1.1 Pole Mounting	7
2.1.2 AK355RPT(RC) Block Diagram	10
2.1.3 Grounding Information	10
2.1.4 5-Pin Surge Protector Module Information	11
2.1.5 Outside Plant Pair Wiring Information.....	11
2.1.6 Internal Equipment Wiring Information	12
2.1.7 Maintenance.....	12
Chapter 3	13
AK5RS	13
3.1 AK5RS Installation	14
3.1.1 AK5RS Block Diagram	15
3.1.2 Grounding Information	15
3.1.3 5-Pin Surge Protector Module Information	16
3.1.4 Outside Plant Pair Wiring Information.....	17
3.1.5 Internal Equipment Wiring Information	17
3.1.6 Maintenance.....	17
Chapter 4	18
Technical Specifications	18
4.1 AK355RPT(RC) Technical Specifications	19
4.2 AK5RS Technical Specifications	20
Chapter 5	21
Warranty and Customer Service	21
Chapter 6	23
Positron Products	23
Appendices	26
Appendix A:	27
Powering Considerations	27

Chapter 1

AIR Series Overview

1.1 Introduction

The AIR regenerators are line-powered mid-span systems in hardened enclosures that can be deployed in indoor or outside plants. The AIR regenerators are compliant with IEEE 802.3ah EFM, IEEE 802.1/802.3 LAN protocol standards and Metro Ethernet Forum (MEF9, MEF14, MEF17). The AIR regenerators include the AK355RPT, AK355RPT E, AK355RPTRC, AK355RPTRC E, and the AK5RS models.

The AK355RPT regenerator is a 16 Pair system that works in conjunction with AK355CP and AK355R units delivering DS3 or Ethernet services supporting both symmetric and asymmetric bandwidths and extending the reach of the AK355 in Carrier Ethernet/DS3 mode. AK355RPT regenerator systems are ideal in Network deployment scenarios with reverse ADSL anomalies.

The AK355RPT E model regenerator is a 16 Pair system that works in conjunction with AK355CP E and AK355R E units delivering only Ethernet services.

The AK355RPTRC model regenerator is a 16 Pair system that works in conjunction with AK355CP and AK355RP units delivering DS3 or Ethernet services. It supports both symmetric and asymmetric bandwidths extending the reach of the AK355 in Carrier Ethernet/DS3 mode up to twice the distance of the CSA 12Kft reach by using a flexible symmetric or asymmetric second span bandwidth configuration. The AK355RPTRC regenerators can also be cascaded to support ultra long reach applications.

The AK355RPTRC E model regenerator is a 16 Pair system that works in conjunction with AK355CP E and AK355RP E units delivering only Ethernet services.

The AK5RS regenerator is an 8 Pair system that works in conjunction with AK525CUP and AK525RU units delivering Ethernet services supporting both symmetric and asymmetric bandwidths. AK5RS is ideal for applications demanding high bandwidth where copper pairs are scarce and also in Network deployment scenarios with reverse ADSL anomalies.

Chapter 2

AK355RPT(RC)

2.1 AK355RPT(RC) Installation



Figure 1 Pole Mounted AK355RPT(RC)

2.1.1 Pole Mounting

Use this procedure to mount the cabinet on a 6 to 8 inch diameter pole.

2.1.1.1 *Required Equipment*

Have the following equipment ready before beginning this procedure:

- 1 - Drill with 3/4" x 12" drill bit
- 1 - 9/16" wrench
- 2 - 15/16" wrenches
- 1 - 7/16" wrench
- 1 - Pencil

2.1.1.2 **Assembly Diagram**

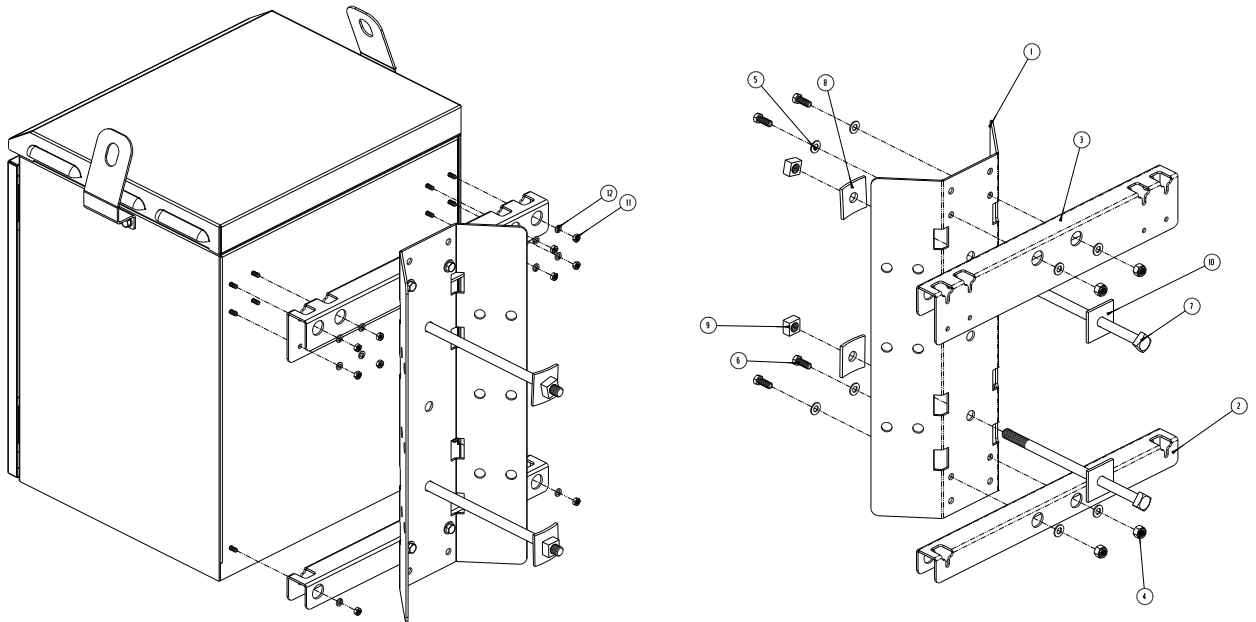

Figure 2 Pole Mounting Kit Assembly

ITEM NO.	QTY.	PART NO.	DESCRIPTION
1	1	S10600-055	BRACKET, VERTICAL POLE MOUNT, ACCESS
2	1	S10600-054	BRACKET, LOWER POLE MOUNT, ACCESS
3	1	S10600-053	BRACKET, UPPER POLE MOUNT, ACCESS
4	4	H38CPSLNNIZ	Nut, Nylon Top Lock 3/8"
5	8	H38NSSFW	Washer, 3/8" Stainless Steel, SAE, Flat
6	4	H38C100SSMSHH	Screw, 3/8-16 x 1", Stainless Steel, Cap
7	2	H63C1600PSSHGV	Bolt, Square Head, 5/8-11 x 16 & Nut, Galvanized
8	2	H63NPSCWGV	Washer, Curved, 2 1/4 x 2 1/4 x 3/16, 5/8, Galvanized
9	2	H63NUT	Nut, 5/8, Galvanized (Included with Bolt)
10	2	H63NPSSWGV	Washer, Square, 2 1/4 x 2 1/4 x 3/16, 5/8, Galvanized
11	10	H25CSSHN	NUT, 1/4-20, HEX, STAINLESS STEEL
12	10	H25NSSLWSP	WASHER, 1/4 SPLIT LOCK, STAINLESS STEEL

Figure 3 Pole Mounting Kit Components

2.1.1.3 **Assembly and Mounting Instructions**

1. Pre-assemble the upper and lower horizontal brackets to the vertical bracket as shown in Figure 2.
2. Select a convenient mounting location on the pole.
3. Position the mounting bracket assembly against the pole and mark on the pole the location of the two (2) 5/8" bolts.
4. Place the mounting bracket assembly out of the way.
5. Drill two 3/4" (19.05 mm) diameter holes completely through the pole at the locations marked in Step 2.
6. Insert machine bolt through mounting bracket and into the top mounting hole and press bolt and bracket flush against the pole.
7. Place round-cupped washer, with the concave side in, on bolt and finger tighten nut.
8. Repeat Step 6 for remaining bolt.
9. Secure the mounting bracket assembly to the pole by securely tightening the machine bolts to 40 ft-lbs for wooden posts and 100 ft-lbs for metal posts.
10. Using proper lifting and safety equipment, place cabinet on mounting bracket assembly using supplied 3/8" hardware and tighten to 45 ft lbs. Lifting eyelets are provided on the cabinet for hoisting it in place.

If the cable stubs connect to an underground cable, dress the cable down the pole. If the cable stubs connect to an aerial cable, form a drip loop in the cable and dress it up the pole to the splice case.



For mounting heights less than 7' above grade, excess bolt length may need to cut off in order to prevent a hazardous protrusion.



Lifting eyelets are provided to facilitate hoisting if desired.

2.1.2 **AK355RPT(RC) Block Diagram**

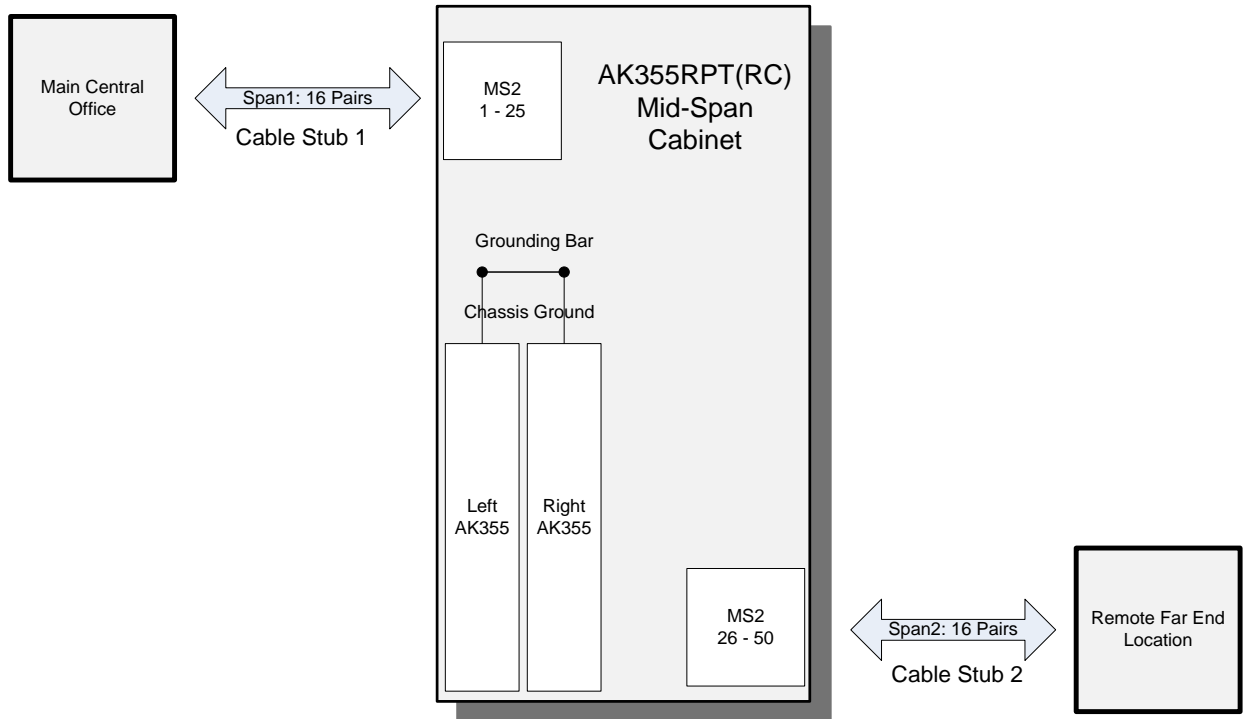

Figure 4 AK355RPT(RC) Block Diagram

2.1.3 **Grounding Information**

Bonding and grounding should be done in accordance with standard procedures and comply with local electrical codes. The internal AK355 units have their chassis grounds connected to the cabinet grounding bar (see Figure 4). Use a 6 or 8 AWG ground cable with a resistance less than 25Ohms.

The ground wire protects the electronics from voltage surges. A #6 ground wire must be properly grounded to provide lightning surge protection for the cabinet. Please follow this practice for attaching the ground unless local policies dictate otherwise.

For safety and performance reasons it is imperative that an AK355RPT(RC) cabinet be properly grounded. The following guidelines should be used to ground the cabinet unless local practices, rules, or regulations dictate otherwise.

Each door and equipment rack is grounded to the cabinet frame. The cabinet frame is connected to the internal grounding bus by a stranded wire. A similar ground wire must be used to connect the ground bus to each equipment ground lug. These ground wires may need to be removed temporarily to troubleshoot ground faults. The wire may be removed by unscrewing the screws that secure the green wire to the ground bus.

Be sure to reattach these wires after troubleshooting and resolving any ground conflicts.

Be sure to ground the AK355RPT(RC) cabinet before connecting power to the cabinet. This grounding must be in effect at all times to safeguard personnel.

2.1.4 5-Pin Surge Protector Module Information

High voltage Surge Protector Modules need to be supplied separately.

High voltage Surge Protector Modules 1 through 16 are used for the Span 1, and Surge Protector Modules 26 through 41 are used for the Span 2.

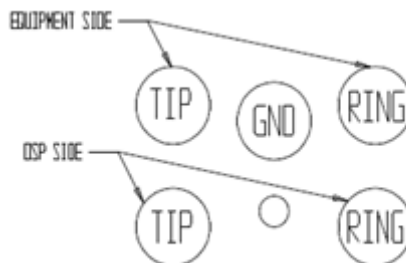

Figure 5 Protector Pin Layout

2.1.5 Outside Plant Pair Wiring Information

The orientation of the AK355 units in the mid-span cabinet is such that the Span 1 Pairs coming from the Main CO connect to the left AK355 unit and the Span 2 Pairs coming from the Remote Far End connect to the right AK355 unit.

A separate cable stub is to be used for each of the spans and to be wired as specified below:

For Span 1 Pairs: Splice Pairs 1-16 onto the MS2 connector labeled 1-25.

For Span 2 Pairs: Splice Pairs 1-16 onto the MS2 connector labeled 26-50.

2.1.6 **Internal Equipment Wiring Information**

The AK355RPT(RC) cabinet has the following prewired internal connections:

- The Ethernet Management Ports between the two AK355 units are cross-connected
- Ethernet Data Port 1 on each AK355 unit is cross-connected
- The DS3 data ports between the two AK355 units are cross-connected

2.1.7 **Maintenance**

2.1.7.1 ***Fans***

The AK355RPT(RC) contain two internal AK355 units each with their own fan assembly. Fans can be replaced in the event of a fan failure or when a fan failure alarm occurs. The AK355RPT(RC) also contains a cabinet fan which is also replaceable. If in case the fans need to be replaced please contact Positron Access Technical support.

2.1.7.2 ***Filters***

The internal AK355 units each have their own filters and these should be replaced every 6 months as needed. The AK355RPT(RC) has its own cabinet filter which should be vacuumed as needed.

Chapter 3

AK5RS

3.1 AK5RS Installation



Figure 6 AK5RS Regenerator

3.1.1 AK5RS Block Diagram

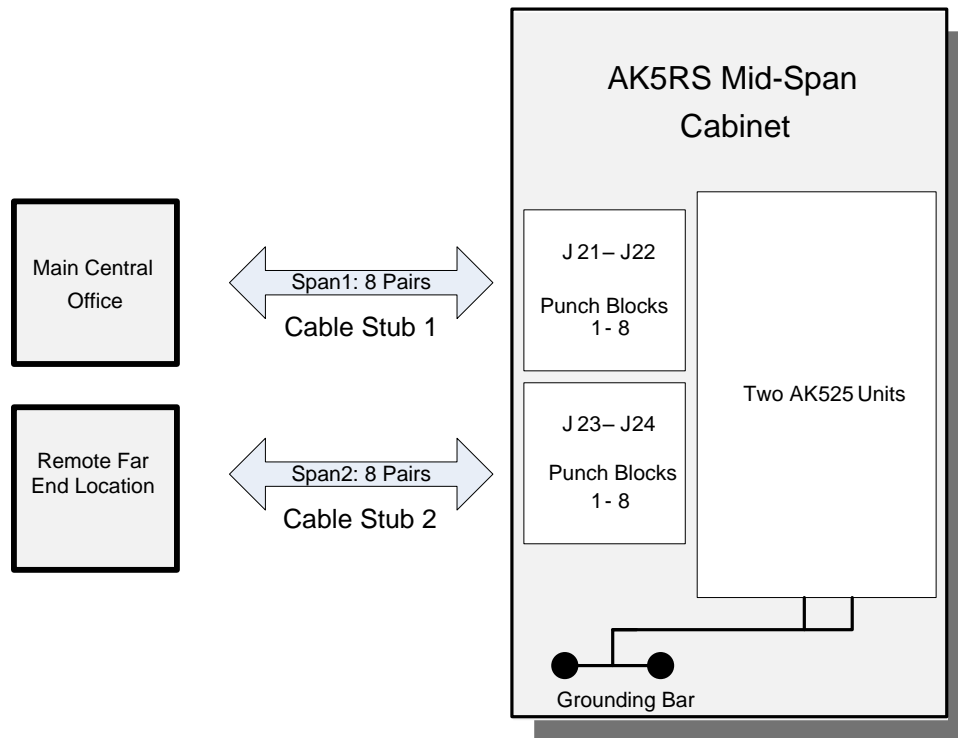

Figure 7 AK5RS Block Diagram

3.1.2 Grounding Information

Bonding and grounding should be done in accordance with standard procedures and comply with local electrical codes. The internal AK525 units have their chassis grounds connected to the cabinet grounding bar (see Figure 7)

Use a 6 or 8 AWG ground cable with a resistance less than 250hms.

The ground wire protects the electronics from voltage surges. A #6 ground wire must be properly grounded to provide lightning surge protection for the cabinet. Please follow this practice for attaching the ground unless local policies dictate otherwise.

For safety and performance reasons it is imperative that an AK5RS cabinet be properly grounded. The following guidelines should be used to ground the cabinet unless local practices, rules, or regulations dictate otherwise.

Each door and equipment rack is grounded to the cabinet frame. The cabinet frame is connected to the internal grounding bus by a stranded wire. A similar ground wire must be used to connect the ground bus to each equipment ground lug. These ground wires may need to be removed temporarily to troubleshoot ground faults. The wire may be removed by unscrewing the screws that secure the green wire to the ground bus.

Be sure to reattach these wires after troubleshooting and resolving any ground conflicts.

Be sure to ground the AK5RS cabinet before connecting power to the cabinet. This grounding must be in effect at all times to safeguard personnel.

3.1.3 **5-Pin Surge Protector Module Information**

High voltage Surge Protector Modules need to be supplied separately.

High voltage Surge Protector Modules 1 through 8 are used for the Span 1, and Surge Protector Modules 9 through 16 are used for the Span 2.

Span 1 uses the top set of surge protectors, with Pair 1 at the bottom right and Pair 2 at the top right. Pairs 3 through 8 move to the left and these eight protectors are labeled J1 – J8.

Span 2 uses the bottom set of surge protectors, with Pair 1 at the top left and Pair 2 at the bottom left. Pairs 3 through 8 move to the right and these eight protectors are labeled J9 – J16.

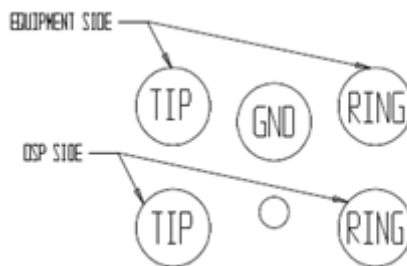

Figure 8 Protector Pin Layout

3.1.4 **Outside Plant Pair Wiring Information**

The orientation of the AK525 units in the mid-span cabinet is such that the Span 1 Pairs coming from the Main CO connect to the bottom AK525 unit and the Span 2 Pairs coming from the Remote Far End connect to the top AK525 unit.

Using the 110 punch blocks:

- Span 1 Pairs 1-4 are on J21
- Span 1 Pairs 5-8 are on J22
- Span 2 Pairs 1-4 are on J23
- Span 2 Pairs 5-8 are on J24

3.1.5 **Internal Equipment Wiring Information**

The AK5RS cabinet has the following prewired internal connections:

- The Ethernet Management Ports between the two AK525 units are cross-connected
- Ethernet Data Port 1 on each AK525 unit is cross-connected

3.1.6 **Maintenance**

3.1.6.1 ***Fans***

The AK5RS contains two internal AK525 units each with their own fan assembly. Fans can be replaced in the event of a fan failure or when a fan failure alarm occurs.

3.1.6.2 ***Filters***

The internal AK525 units each have their own filters and these should be replaced every 6 months as needed. The AK5RS has its own cabinet filter which should be vacuumed as needed.

Chapter 4

Technical Specifications

4.1 **AK355RPT(RC) Technical Specifications**

General Features

- Two AK355 equipment slots
- DS3 45Mbps - Channelized/ Clear Channel at 25 Kft/ 7.6 Km
- ATM over DS3 30 Kft / 9.1 Km
- Carrier Ethernet Symmetric and Asymmetric services
- Extended reach beyond 30 Kft/ 9.1Km
- System Latency: 4 ms
- Resiliency: Carrier Grade Automatic Pair Failure Protection
- BER: 10^{-12}

Outside Plant Pairs

- Number of Pairs: Up to 16
- Sealing Current: Meets G991.2
- T1.417 (Spectral) Compliant

Electrical Specifications

- Line Powered
- Maximum Heat Dissipation: 185 Watts

Environmental Specifications

- Operating Temperature: -40 to +65°C
- Storage Temperature: -40 to +70°C
- Relative Humidity: Up to 95%, non-condensing

Mechanical Specifications

- Dimensions: 26" high x 15" wide x 13" deep
- Weight: Approximately 40 lbs

Regulatory Approval

- NEBS Level 3
- UL60950
- FCC Part 15 Class A

Network Management

- AktinoView or Aktino EMS
- Inband VLAN or ATM Management

4.2 AK5RS Technical Specifications

General Features

- Two AK525 equipment slots
- Environmentally hardened industrial grade regenerator
- Extended reach beyond 30 Kft/ 9.1Km
- Symmetric and Asymmetric services
- System Latency: 4 ms
- BER: 10^{-12}

Outside Plant Pairs

- Number of Pairs: up to 8 pairs
- Sealing Current: Meets G991.2

Electrical Specifications

- Line Powered
- Max Heat Dissipation: 90 Watts

Environmental Specifications

- Operating Temperature: -40 to +65°C
- Storage Temperature: -40 to +70°C
- Relative Humidity: Up to 95%, non-condensing

Mechanical Specifications

- Dimensions: 19" High x 15" Wide x 6" Deep
- Weight: Approximately 20 lbs

Regulatory Approval

- NEBS Level 3
- UL60950
- FCC Part 15 Class A

Network Management

- AktinoView or Aktino EMS
- Inband VLAN Management

Chapter 5

Warranty and Customer Service

Positron will replace or repair this product within the warranty period if it does not meet its published specifications or fails while in service. Warranty information can be found in your Positron customer web portal:

<http://portal.positronaccess.com/login.asp>

Positron Sales Pricing/Availability

949-258-0545

Positron Technical Support

Pre-Sales Applications/Post-Sales Technical Assistance:

1-888-258-4669

949-258-0545 option 5

7days/week, 24 hours/day

Positron Repair

Return for Repair/Upgrade:

949-258-0545

<http://ticketmaster.positronaccess.com/>

Repair and Return Address

Contact Customer Service prior to returning equipment to Positron.

Positron Access Systems, Inc.

4931 Birch Street

Newport Beach CA 92660

Chapter 6

Positron Products

Positron AIR Products and Accessories

Part Number	Description
AK355RPT Products	
AK355RPT	AIR AK355 Regenerator, DS3/Ethernet
AK355RPT E	AIR AK355 Regenerator, Ethernet Only
AK355C P	AK355 CO Unit DS3/Ethernet, 45Mbps DS3 and up to 100Mbps Ethernet at CSA, with Line Power Option
AK355C PE	AK355 CO Unit, Ethernet Only up to 100Mbps at CSA, with Line Power Option
AK355R	AK355 RT Unit, DS3/Ethernet, 45Mbps DS3 and up to 100Mbps Ethernet at CSA, Local Powered or Line Powered
AK355R E	AK355 RT Unit, Ethernet Only up to 100Mbps at CSA, Local Powered or Line Powered
AK300FAN	Fan Asy, Spare AK300/355/555
AK300FL6	AK355 Air Filter (6-Pack)
AK355RPTFAN	AK355RPT Regenerator SPC TP30 Cabinet Fan Kit

Part Number	Description
AK355RPTRC Products	
AK355RPTRC	AIR AK355 Regenerator, DS3/Ethernet, Reverse Line Powered
AK355RPTRC E	AIR AK355 Regenerator, Ethernet Only, Reverse Line Powered
AK355C P	AK355 CO Unit DS3/Ethernet, 45Mbps DS3 and up to 100Mbps Ethernet at CSA, with Line Power Option
AK355C PE	AK355 CO Unit, Ethernet Only up to 100Mbps at CSA, with Line Power Option
AK355RP	AK355 RT Unit DS3/Ethernet Unit, 45Mbps DS3 and up to 100Mbps Ethernet at CSA, with Line Power Option
AK355RP E	AK355 RT Unit, Ethernet Only up to 100Mbps at CSA, with Line Power Option
AK300FAN	Fan Asy, Spare AK300/355/555
AK300FL6	AK355 Air Filter (6-Pack)
AK355RPTFAN	AK355RPT Regenerator SPC TP30 Cabinet Fan Kit

Positron AIR Products and Accessories

Part Number	Description
AK5RS Products	
AK5RS	AIR Inclusive 8 pair Ethernet Regenerator incl housing (New Light Weight Cabinet)
AK525RU	Compact Remote Unit (CRU) 8-Pair
AKCUFAN	Compact Remote Unit (CRU) Fan Assembly
AKCUFILT	Compact Unit Air Filters (6 Pack)

Appendices

Appendix A:

Powering Considerations

Single AK355RPT

A single AK355RPT regenerator typically works in conjunction with two locally powered AK355CP units, one at the Main Central Office and one at the Remote Far End. In this deployment each AK355CP supplies Line Power so the AK355RPT regenerator requires no local power.

The AK355NTE01 cabinet can be used for the AK355CP connected to Span 2 in the event it needs its own cabinet.

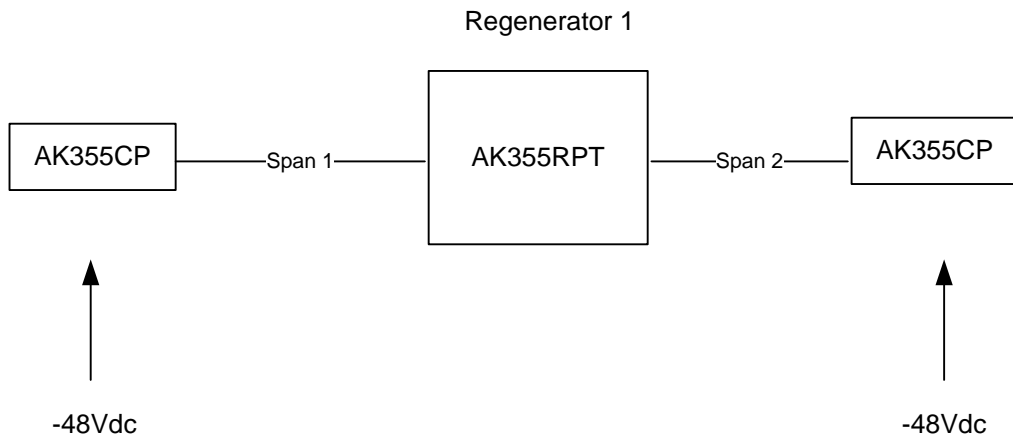

Single AK355RPT Regenerator Product List	Description
2 x AK355C P	AK355 CO Unit DS3/Ethernet, 45Mbps DS3 and up to 100Mbps Ethernet at CSA, with Line Power Option
AK355RPT	AIR AK355 Regenerator, DS3/Ethernet
AK355NTE01 (Optional)	TP30 cabinet with fan and cable assembly only.

Single AK355RPTRC

A single AK355RPTRC regenerator typically works in conjunction with a locally powered AK355CP unit at the Main Central Office and a locally powered AK355RP unit at the Remote Far End. In this deployment the AK355CP and AK355RP units supply Line Power so the AK355RPTRC regenerator requires no local power.

The AK355NTE01 cabinet can be used for the AK355RP connected to Span 2 in the event it needs its own cabinet.

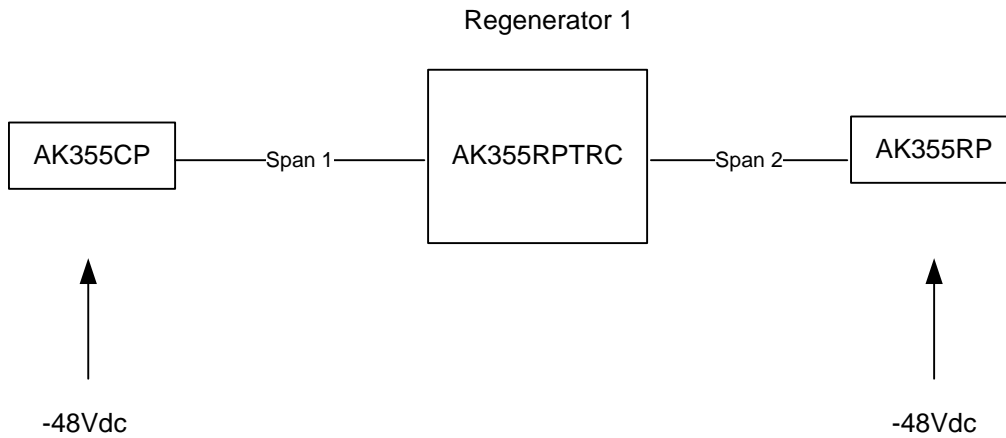

Single AK355RPTRC Regenerator Product List	Description
AK355C P	AK355 CO Unit DS3/Ethernet, 45Mbps DS3 and up to 100Mbps Ethernet at CSA, with Line Power Option
AK355RPTRC	AIR AK355 Regenerator, DS3/Ethernet, Reverse Line Powered
AK355RP	AK355 RT Unit DS3/Ethernet Unit, 45Mbps DS3 and up to 100Mbps Ethernet at CSA, with Line Power Option
AK355NTE01 (Optional)	TP30 cabinet with fan and cable assembly only.

Cascaded Regenerators

Regenerator 1 Locally Powered

For ultra long reach applications the AK355RPTRC regenerator can be used in conjunction with another regenerator expanding the reach to three spans. In double regenerator deployments either the first or second regenerator needs to be locally powered with -48Vdc. In deployments where the first regenerator is locally powered, local power is also required for the AK355CP at the Main CO and at the AK355RP at the Remote Far End. The AK355NTE01 cabinet can be used for Regenerator 1 and the AK355RP connected to Span 3.

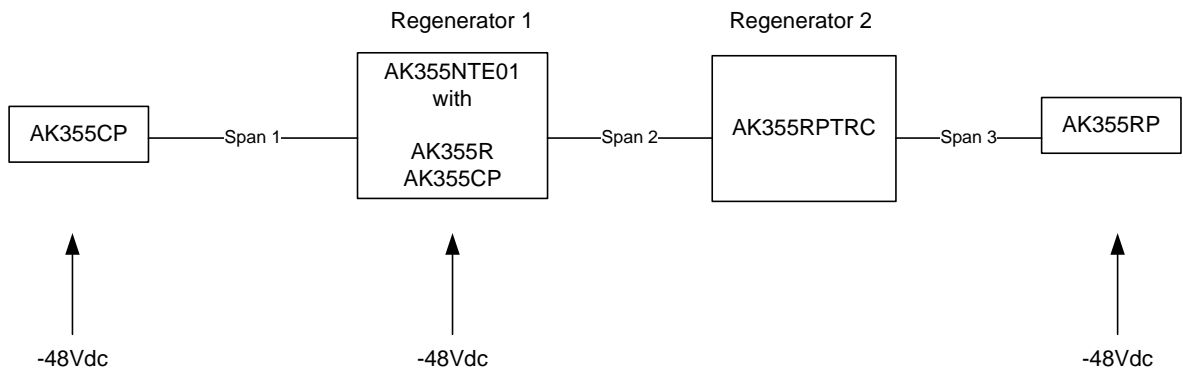

Cascaded Regenerators product list with Regenerator 1 locally powered	Description
AK355C P	AK355 CO Unit DS3/Ethernet, 45Mbps DS3 and up to 100Mbps Ethernet at CSA, with Line Power Option
AK355R	AK355 RT Unit, DS3/Ethernet, 45Mbps DS3 and up to 100Mbps Ethernet at CSA, Local Powered or Line Powered
AK355C P	AK355 CO Unit DS3/Ethernet, 45Mbps DS3 and up to 100Mbps Ethernet at CSA, with Line Power Option
AK355RPTRC	AIR AK355 Regenerator, DS3/Ethernet, Reverse Line Powered
AK355RP	AK355 RT Unit DS3/Ethernet Unit, 45Mbps DS3 and up to 100Mbps Ethernet at CSA, with Line Power Option
AK355NTE01 (Optional)	TP30 cabinet with fan and cable assembly only.

Cascaded Regenerators

Regenerator 2 Locally Powered

For ultra long reach applications the AK355RPTRC regenerator can be used in conjunction with another regenerator expanding the reach to three spans. In double regenerator deployments either the first or second regenerator needs to be locally powered with -48Vdc. In deployments where the second regenerator is locally powered, local power is also required for the AK355CP at the Main CO and the AK355R at the Remote Far End. The AK355NTE01 cabinet can be used for Regenerator 1 and the AK355R connected to Span 3.

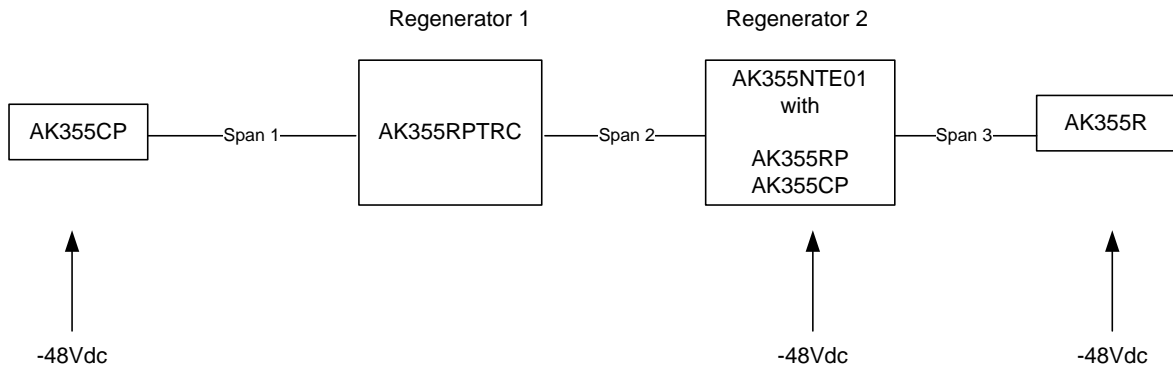

Cascaded Regenerators product list with Regenerator 2 locally powered	Description
AK355C P	AK355 CO Unit DS3/Ethernet, 45Mbps DS3 and up to 100Mbps Ethernet at CSA, with Line Power Option
AK355RPTRC	AIR AK355 Regenerator, DS3/Ethernet, Reverse Line Powered
AK355RP	AK355 RT Unit DS3/Ethernet Unit, 45Mbps DS3 and up to 100Mbps Ethernet at CSA, with Line Power Option
AK355C P	AK355 CO Unit DS3/Ethernet, 45Mbps DS3 and up to 100Mbps Ethernet at CSA, with Line Power Option
AK355R	AK355 RT Unit, DS3/Ethernet, 45Mbps DS3 and up to 100Mbps Ethernet at CSA, Local Powered or Line Powered
AK355NTE01 (Optional)	TP30 cabinet with fan and cable assembly only.
AK355NTE00 (Optional)	TP30 cabinet with fan, cable assembly and AK355R RT DS3/Ethernet unit, 45Mbps DS3 and up to 100Mbps Ethernet at CSA, Local or Line Powered.